

This article was downloaded by:

On: 25 January 2011

Access details: *Access Details: Free Access*

Publisher *Taylor & Francis*

Informa Ltd Registered in England and Wales Registered Number: 1072954 Registered office: Mortimer House, 37-41 Mortimer Street, London W1T 3JH, UK

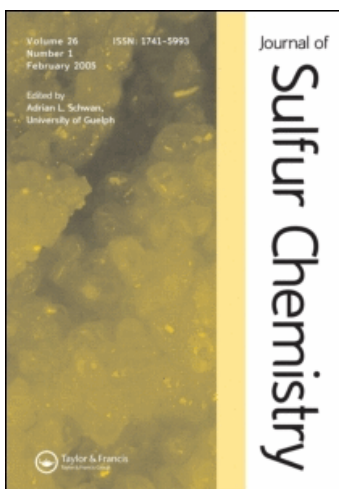

Journal of Sulfur Chemistry

Publication details, including instructions for authors and subscription information:

<http://www.informaworld.com/smpp/title~content=t713926081>

Reactions of Organic Sulfur Compounds at Electrodes

Ole Hammerich^a; Vernon D. Parker^b

^a Department of General and Organic Chemistry, The H. C. Østed Institute, University of Copenhagen, Copenhagen, Denmark ^b Organic Chemistry Laboratories, Norwegian Institute of Technology, University of Trondheim, Trondheim-NTH, Norway

To cite this Article Hammerich, Ole and Parker, Vernon D.(1981) 'Reactions of Organic Sulfur Compounds at Electrodes', *Journal of Sulfur Chemistry*, 1: 6, 317 – 390

To link to this Article: DOI: 10.1080/01961778108082418

URL: <http://dx.doi.org/10.1080/01961778108082418>

PLEASE SCROLL DOWN FOR ARTICLE

Full terms and conditions of use: <http://www.informaworld.com/terms-and-conditions-of-access.pdf>

This article may be used for research, teaching and private study purposes. Any substantial or systematic reproduction, re-distribution, re-selling, loan or sub-licensing, systematic supply or distribution in any form to anyone is expressly forbidden.

The publisher does not give any warranty express or implied or make any representation that the contents will be complete or accurate or up to date. The accuracy of any instructions, formulae and drug doses should be independently verified with primary sources. The publisher shall not be liable for any loss, actions, claims, proceedings, demand or costs or damages whatsoever or howsoever caused arising directly or indirectly in connection with or arising out of the use of this material.

REACTIONS OF ORGANIC SULFUR COMPOUNDS AT ELECTRODES

OLE HAMMERICH

*Department of General and Organic Chemistry, The H. C. Ørsted Institute, University of
Copenhagen, DK-2100 Copenhagen, Denmark*

VERNON D. PARKER

*Organic Chemistry Laboratories, Norwegian Institute of Technology, University of
Trondheim, N-7034 Trondheim-NTH, Norway*

The redox behavior of organic sulfur compounds at electrodes is reviewed emphasizing synthetic, structural and mechanistic aspects of the reactions. A wide variety of electrode reactions are covered including a number of novel syntheses and some detailed mechanism studies. Electroreduction of carbon disulfide provides the useful intermediate, 2-thioxo-1,3-dithiol-4,5-dithiolate. Oxidation of a number of sulfur compounds results in the formation of dimers. Reductive dimerization is an important reaction of sulfur containing heterocyclic cations. A number of bond cleavages involving either C—S or S—S bonds have been studied and many are integral parts of synthetic procedures. Transformation of sulfur containing functional groups by changes in the oxidation state of sulfur can be carried out in both oxidative and reductive processes.

TABLE OF CONTENTS

I. GENERAL INTRODUCTION	319
II. ELECTROCHEMICAL METHODS	319
1. <i>Controlled Potential and Controlled Current Electrolysis.</i>	319
2. <i>Cyclic Voltammetry.</i>	319
3. <i>Coulometry.</i>	320
4. <i>Polarography and Rotating Electrode Voltammetry.</i>	321
5. <i>Electrode Kinetics and Mechanism Analysis.</i>	323
III. CARBON DISULFIDE AS A BUILDING BLOCK	323
1. <i>Introduction.</i>	323
2. <i>Synthetic Applications of Carbon Disulfide Reduction.</i>	323
3. <i>The Mechanism of the Cathodic Reduction of CS₂.</i>	324
IV. ELECTRODE REACTIONS OF THIOCARBONATES	325
1. <i>Introduction.</i>	325
2. <i>Oxidation Reactions.</i>	325
3. <i>Reduction Reactions.</i>	326
4. <i>The Electron Transfer Reaction.</i>	329
V. THIOOXALATES	330

VI. SULFUR CONTAINING HETEROCYCLIC CATIONS	332
1. <i>Trithiocarbenium Ions.</i>	332
2. <i>1,3-Dithiolylium Ions.</i>	332
3. <i>1,2-Dithiolylium Ions.</i>	333
4. <i>Thiopyrylium Ions.</i>	335
VII. TETRATHIOETHYLENES	336
VIII. THIOCARBOXYLATES AND THIOESTERS	339
1. <i>Thiocarboxylates.</i>	339
2. <i>Thioesters.</i>	340
IX. 1,2-DITHIOLE-3-THIONES AND RELATED COMPOUNDS	344
1. <i>1,2-Dithiole-3-thiones.</i>	344
2. <i>α-(1',2'-Dithiol-3'-ylidene)acetophenones.</i>	345
3. <i>1,6,6aλ⁴-Trithiapentalenes.</i>	346
X. 1,4-DITHIINS AND BENZODERIVATIVES	347
1. <i>1,4-Dithiins and 2,3-Benzo-1,4-dithiin.</i>	347
2. <i>Thianthrenes and Related Compounds.</i>	347
XI. THIOPHENES AND BENZODERIVATIVES	353
1. <i>Oxidation in Methanol.</i>	353
2. <i>Thioindigo.</i>	354
3. <i>Dibenzothiophene.</i>	356
XII. THIOLS AND DISULFIDES	356
1. <i>Introduction.</i>	356
2. <i>The Thiol-Disulfide Redox System.</i>	356
3. <i>The Role of Mercury in the Electrode Processes.</i>	358
4. <i>Sulfur Containing Amino Acids.</i>	359
5. <i>Reduction of Thiols.</i>	360
6. <i>Oxidation of Disulfides.</i>	361
XIII. SULFIDES	361
1. <i>Introduction.</i>	361
2. <i>Oxidation in Aprotic Solvents. The Formation of Cation Radicals and Sulfonium Salts.</i>	362
3. <i>Oxidation in Protic Solvents. The Formation of Sulfoxides and Sulfones.</i>	367
4. <i>Thioacetals.</i>	368
5. <i>Miscellaneous Oxidations of Sulfides.</i>	369
6. <i>Reduction of Sulfides.</i>	370
XIV. SULFONIUM SALTS	373
XV. THIOKETONES	375
1. <i>Reduction of Thioketones.</i>	375
2. <i>Oxidation of Thioketones.</i>	376
XVI. SULFOXIDES	376
1. <i>Reduction of Sulfoxides.</i>	376
2. <i>Oxidation of Sulfoxides.</i>	377

XVII. SULFONES	378
1. <i>Anion Radical Formation and Mechanisms of Further Reactions.</i>	378
2. <i>Product Distribution from Reductions of Diaryl and Aryl Alkyl Sulfones.</i>	380
3. <i>Di- and Trisulfones.</i>	381
4. <i>Sulfones Containing Other Functional Groups.</i>	382
5. <i>Unsaturated Sulfones.</i>	383
XVIII. DERIVATIVES OF SULFUR CONTAINING ACIDS	383
XIX. THE PRESENT STATE OF THE ELECTROCHEMISTRY OF ORGANIC SULFUR COMPOUNDS	385

I. GENERAL INTRODUCTION

Oxidation and reduction play an important role in the reactions of organic sulfur compounds. The oxidation state of sulfur can vary from -2 to $+6$ giving rise to a very large number of classes of organic sulfur compounds. In recent years, electrode processes have been used to an ever increasing extent in affecting the redox reactions. In addition to the synthetic applications, electrode studies can also provide valuable kinetic and thermodynamic information in the study of mechanisms of the transformations.

Our coverage of the literature of the reactions of organic sulfur compounds at electrodes will be limited to studies relating to synthesis, mechanism and structure. A large body of published material relating to analytical applications will not be included.

The most significant work in the electrochemistry of organic sulfur compounds has appeared since 1965. This review will primarily deal with papers appearing from that time including the first half of 1981. Various aspects of the subject have previously been reviewed.¹⁻⁵

II. ELECTROCHEMICAL METHODS

A brief review of the electrochemical techniques most frequently used in the study of the electrode reactions of organic sulfur compounds is in order. More detail of these and other electrochemical techniques can be found in more specialized reviews.^{6,7}

1. *Controlled Potential and Controlled Current Electrolysis.*

The synthesis of compounds by electrolytic reactions is normally carried out under conditions where either the electrode potential or the current is controlled in order to assure that maximal selectivity is achieved. When controlled potential methods are used it is first necessary to carry out analytical studies to determine the pertinent electrode potentials. Cyclic voltammetry (CV) and polarography are most frequently used for this purpose.

2. *Cyclic Voltammetry.*

During cyclic voltammetry the potential of the electrode where the processes of interest take place, usually called the working electrode, is varied linearly with time in a cyclic

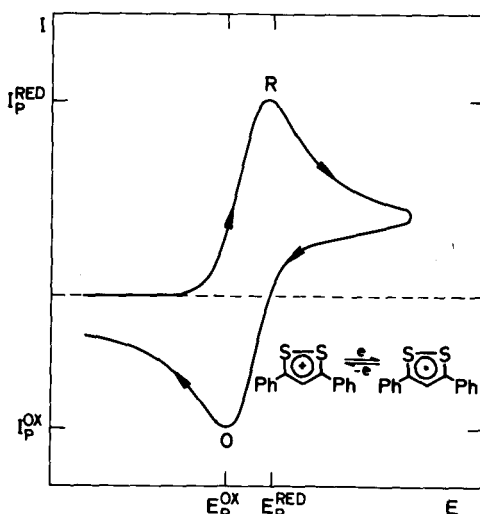

FIGURE 1 Cyclic voltammogram for the reduction of 3,5-diphenyl-1,2-dithiolylium ion in acetonitrile. Voltage sweep rate, 150 mV/s. $E_p^{\text{RED}} = -0.27$ V vs. SCE. $|E_p^{\text{RED}} - E_p^{\text{OX}}| = 60$ mV.

manner in order to observe the response of the substrate and reaction intermediates. For the case where the product of electron transfer is stable in solution the cyclic voltammogram is of the form of Figure 1. In Figure 1 the peak labelled R is due to the reduction of the 1,2-dithiolylium ion to the moderately stable free radical which is oxidized on the reverse scan at peak O. In addition to providing the electrode potential for the process the cyclic voltammogram also gives an indication of the stability of the intermediate. The relative peak currents at O and R give a measure of the latter and the ratio is 1.0 for the no-reaction case.

When the electron transfer reaction is followed by a rapid chemical reaction the cyclic voltammogram takes the form shown in Figure 2. In this case the 1,2-dithiolylium ion is reduced irreversibly to the dimer at R. On the reverse scan, the dimer is oxidized irreversibly to regenerate the substrate at O. This is an illustration of the detection of the reaction product during cyclic voltammetry. Figure 2-b shows the voltammogram after exhaustive electrolysis during which all of the dithiolylium ion is converted to the corresponding dimer.

3. Coulometry.

The determination of the number of electrons per molecule of substrate that is involved in the electrode process, n , is called coulometry. Coulometric n values are important quantities for the determination of mechanisms and also give an indication of efficiency during preparative studies. Coulometry at controlled potential is carried out by integration of current as a function of time during exhaustive electrolysis. Alternatively, the current can be controlled at a low value to insure that the electrode potential remains in the desired range and the consumption of substrate can be determined as a function of time. The latter procedure is demonstrated in Figure 3 where cyclic voltammetry is used to monitor the process. Under the reaction conditions, 6.44 minutes was the calculated electrolysis time necessary to completely consume the 1,2-dithiolylium ion in a one electron reduction process. The intercept of the plot of the peak height as a function of

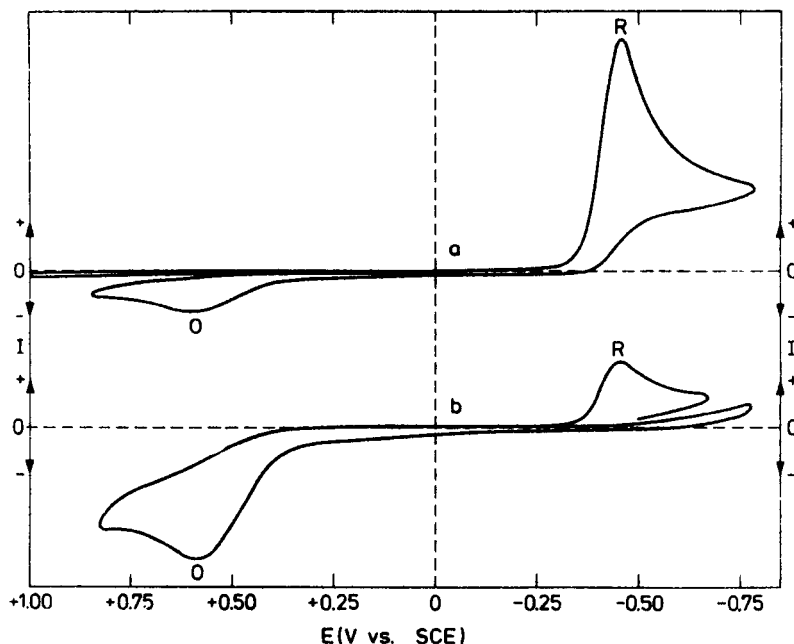

FIGURE 2 Cyclic voltammograms for (a) the reduction of 3,4-diphenyl-1,2-dithiolium ion and (b) the oxidation of the corresponding dimer in acetonitrile. Voltage sweep rate, 150 mV/s. (Reprinted from Ref. 30 by courtesy of Pergamon Press Ltd.).

time gives the electrolysis time which can be used to determine n (equal to 0.96 in this case).

4. Polarography and Rotating Electrode Voltammetry.

In contrast to cyclic voltammetry where mass transport of the substrate to the electrode takes place only by diffusion, polarography and rotating electrode voltammetry involve convective mass transport as well. The current-voltage curve in these cases take the form

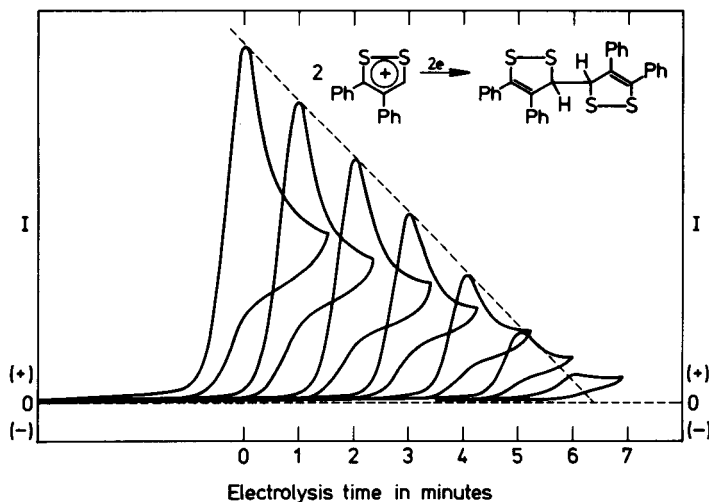

FIGURE 3 Constant current (25 mA) coulometry of 3,4-diphenyl-1,2-dithiolium ion (0.1 mmol) in acetonitrile.

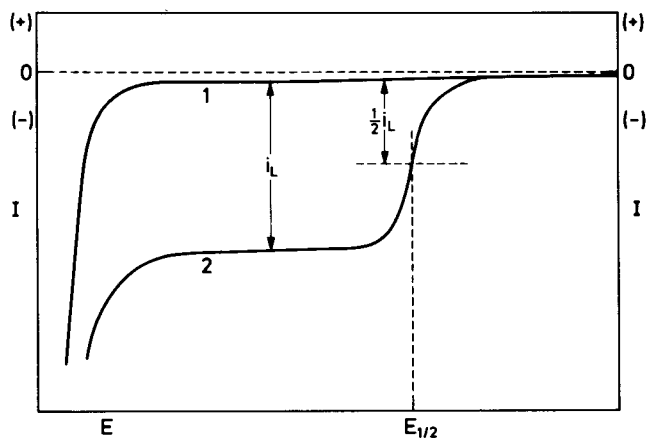

FIGURE 4 Rotating disk electrode voltammograms. (1) Background and (2) in the presence of substrate.

shown in Figure 4. The most pertinent features used in analysis are the limiting current i_L and the half-wave potential $E_{1/2}$. The limiting current is a measure of the number of electrons transferred and the half-wave potential is related to the standard potential at which the process takes place. The rotating ring disk electrode is constructed so that products of the electrode reaction taking place on the disk electrode are swept pass the ring electrode where they can be monitored. The use of the ring disk electrode is demonstrated by the voltammograms shown in Figure 5. The 1,4-dithiin is oxidized on

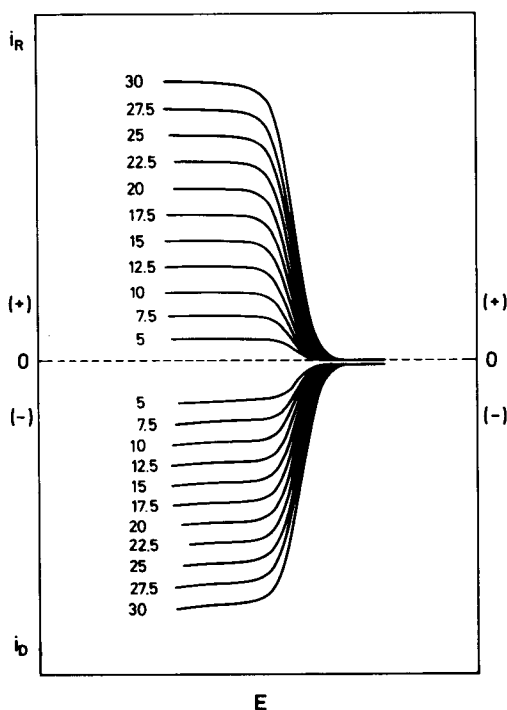

FIGURE 5 Rotating ring-disk voltammogram for the oxidation of 2,5-bis(4-chlorophenyl)-1,4-dithiin in dichloromethane at rotation rates between $\omega^{1/2} = 5$ and $\omega^{1/2} = 30$ ($\omega = 2\pi f$). The current amplification for the ring electrode is five times that for the disk electrode. N ($\omega^{1/2} = 10$) = 0.134 and N ($\omega^{1/2} = 25$) = 0.212.

the disk electrode and the resulting cation radicals can be detected at the ring electrode. The cation radicals undergo a dimer forming reaction at a moderate rate. At low rotation rates the collection efficiency $N (= i_R/i_D)$ is considerably lower than for the no-reaction case which for the particular electrode is equal to 0.213. At higher rotation rates the effect of the chemical reaction is not observed and N is close to the theoretical value for the complete recovery of the cation radical.

5. Electrode Kinetics and Mechanism Analysis.

Some of the studies which will be discussed in this review have employed more sophisticated analyses, the explanations of which are beyond the scope of this review. Reference to detailed discussions of these techniques will be pointed out at the appropriate points in the discussion.

III. CARBON DISULFIDE AS A BUILDING BLOCK

1. Introduction

The electrochemical reduction of carbon disulfide in aprotic solvents provides a convenient route to the 4,5-dimercapto-1,3-dithiole-2-thione dianion (*1*) (Scheme 1).⁸ The dianion (*1*) is produced along with (*2*) during reduction in either *N,N*-dimethylformamide

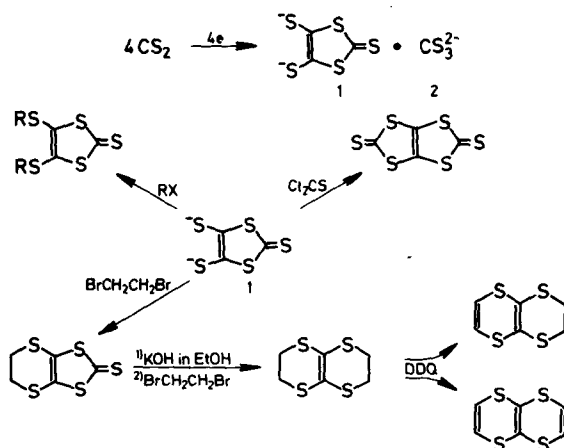

Scheme 1

(DMF) or acetonitrile (AN) and both species were identified by converting to the dimethyl derivatives on reaction with methyl iodide. The same products are obtained by sodium amalgam reduction of CS_2 .⁸ The latter reaction has been studied earlier and the tetrathiooxalate structure was erroneously assigned to the major product.⁹

2. Synthetic Applications of Carbon Disulfide Reduction.

The 1,3-dithiole-2-thione dianion (*1*) has proven to be a versatile building block for other heterocyclic sulfur compounds. The various syntheses are summarized in Scheme 1.

Various alkylated derivatives are readily prepared by reaction with the appropriate alkyl halide.^{10,11} Reaction of (1) with 1,2-dibromoethane, hydrolysis, and further reaction with 1,2-dibromoethane followed by dehydrogenation with dichlorodicyanobenzoquinone (DDQ) gave 1,4,5,8-tetrathiatetralin, a tetrathiafulvalene isomer.¹² Reaction of (1) with thiophosgene gave rise to 1,3,4,6-tetrathiapentalene-2,5-dithione which was of interest as a donor in organic charge transfer salts.¹³ A number of tetrathiafulvalene derivatives have been prepared from (1).¹⁴

3. The Mechanism of the Cathodic Reduction of CS₂.

Wawzonek and Heilmann⁸ suggest that the mechanism of the formation of (1) involves the sequence of reactions shown in Scheme 2. The key step in the mechanism is the

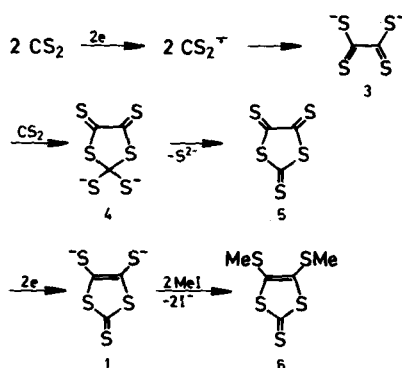

Scheme 2

dimerization of CS₂^{•-} to the tetrathiooxalate which then reacts with substrate to give (4). Loss of sulfide was proposed to give (5) which upon reduction generates the dianion (1). No supporting evidence for this mechanism was presented.

More recently, a more detailed mechanism study has appeared.¹⁵ The cyclic voltammogram of CS₂ in DMF showed an irreversible reduction peak (Figure 6) at -1.96 V (vs. SCE) and on the anodic scan a small peak due to a product was observed at -0.08 V. The anodic peak was described to be of non-diffusive character and interpreted to indicate some adsorption of reaction products. Plots of the peak current vs. substrate concentration and the square root of the voltage sweep rate ($\nu^{1/2}$) were not straight lines as predicted by theory for chemical reactions following charge transfer. The curvature of the plots was taken as a further indication of complications from adsorption of products. Controlled potential coulometry at -2.2 V resulted in an *n* value of 1. The most significant mechanistic evidence came from spectroscopic studies of the reaction mixtures and from product studies. Uv-vis spectral evidence was presented for the formation of CS₃²⁻ which was then isolated as the barium salt and the structure was confirmed by infrared spectral studies. The formation of CS₃²⁻ suggested, in analogy to the reaction pathway for the reduction of CO₂,^{16,17} that CS should be a product as well. In fact, CS was trapped as Ph(Cl)(CS)Rh(PPh₃)₂ in 5% yield. It was concluded that CS undergoes a competing reaction and that the trapping was inefficient. On the basis of the available evidence, the mechanism summarized in Scheme 3 was suggested. The key step in this mechanism is the disproportionation of CS₂^{•-} to CS₃²⁻ and CS. Combination of these two entities then results in the formation of (1). The number of electrons per substrate molecule is predicted to be

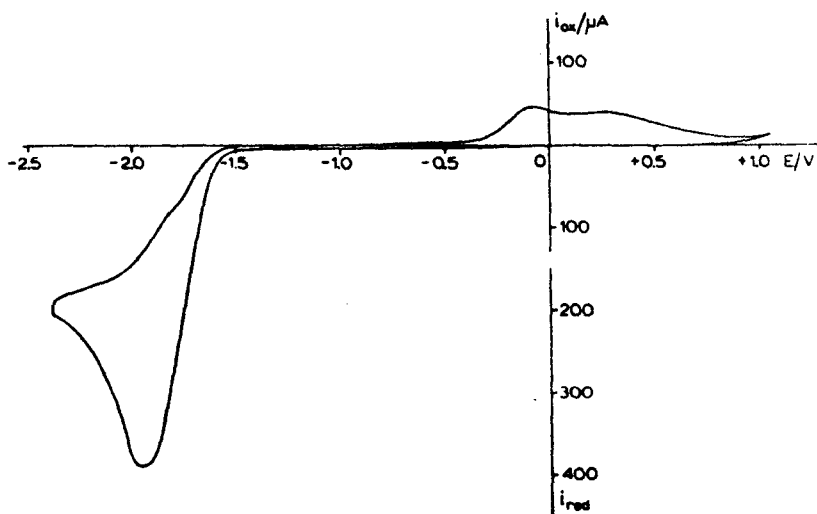
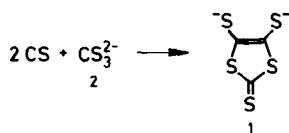
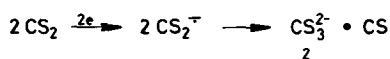

FIGURE 6 Cyclic voltammogram for the oxidation of CS_2 (10^{-2}M) in DMF. Voltage sweep rate, 200 mV/s. (Reprinted from Ref. 15 by courtesy of Elsevier Sequoia S.A.).



Scheme 3

1.0 by this mechanism. On the other hand, Wawzonek and Heilmann's mechanism requires the consumption of 1.33 electrons per molecule of CS_2 reacting. Thus, both the coulometric n value and the isolation of intermediates strongly support the mechanism given in Scheme 3, which can be summarized to give the equation in Scheme 1.

IV. ELECTRODE REACTIONS OF THIOCARBONATES

1. Introduction.

Both open chain and cyclic thiocarbonates have served as substrates for numerous studies involving either oxidations or reductions at electrodes. A central emphasis in the work has been the search for possible synthetic routes to tetrathioethylenes. Open chain derivatives sometimes give tetrathioethylene derivatives during cathodic reduction while the cyclic thiocarbonates do not. Although progress along these lines has been made, the factors determining the reaction pathways followed for the various types of compounds is still not well understood.

2. Oxidation Reactions.

Upon anodic oxidation of ethylene trithiocarbonate (7) in acetonitrile the product isolated was ethylene dithiocarbonate (12).¹⁸ Voltammetric data indicated that the

“short-time” n value was 0.5 which suggested that the initially formed cation radical (8) reacts with substrate to give (9) as indicated in Scheme 4. The next postulated reaction

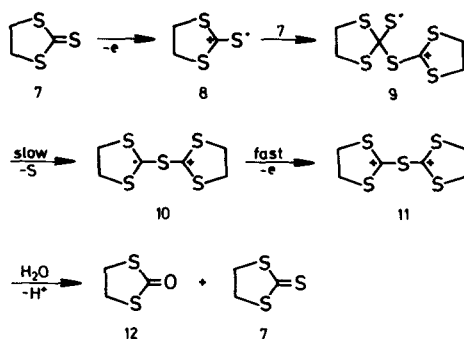

step involves the loss of a sulfur atom to give cation radical (10) which then undergoes further oxidation to dication (11). Finally, hydrolysis gives the product (12) and regenerates substrate. It should be pointed out that the evidence for this reaction scheme is restricted to the voltammetric n value of 0.5 and the nature of the product. What is not clear is whether or not other products are formed and if so how the reaction scheme accounts for their formation.

The work on the oxidation of cyclic trithiocarbonates was extended to a number of other compounds, (6), (13)–(17).¹⁹ Reaction Scheme 4 was assumed to apply to all of these

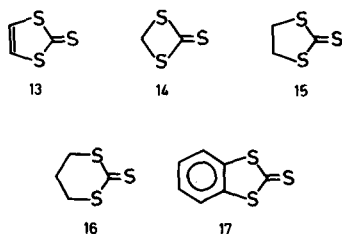

processes. Tetrathioethylenes could not be detected as products in any case. However, it is of interest that oxidation of some of the compounds by AlCl_3 in nitromethane did result in the formation of tetrathioethylenes.

Voltammetric data provided the basis for further mechanistic discussion in support of Scheme 4. However, all peak widths, $E_p - E_{p/2}$, were larger than predicted for kinetic processes following reversible charge transfer. The latter indicates that the voltammetry is a reflection of charge transfer control, at least to some extent, and discussion of the data in terms of the succeeding chemical reactions is highly questionable.

3. Reduction Reactions.

Cyclic voltammetric data were reported for the reduction of (14) to (17). The anion radicals of (15) to (17) could be detected at high sweep rates and weak esr signals were observed when the reductions were carried out in the spectrometer cavity.¹⁹ Preparative scale reductions²⁰ in DMF at platinum electrodes followed by alkylation with methyl iodide gave (24) while alkylation with ethylene dibromide resulted in the formation of

(23). On the basis of the products observed, Scheme 5 was suggested for the mechanism of

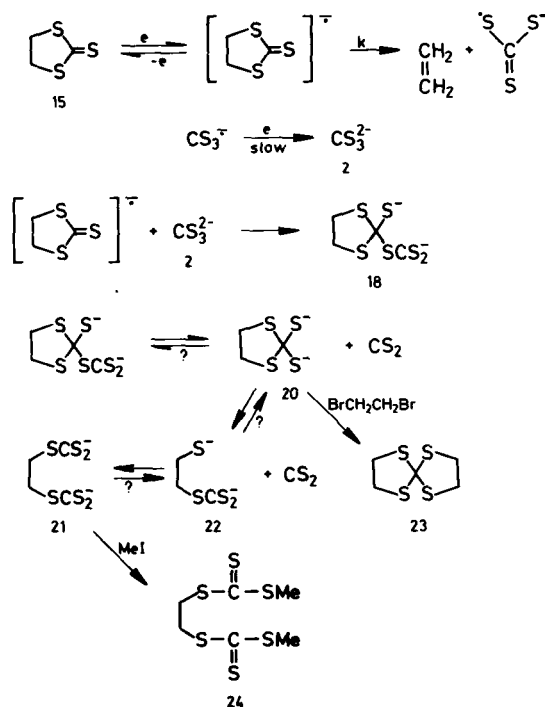

Scheme 5

the reduction. Needless to say, the mechanism can only be considered to be a working hypothesis since little or no evidence is presented for the various reaction intermediates.

In contrast to the behavior of the cyclic trithiocarbonates, reduction of a number of open chain dialkyl trithiocarbonates, Scheme 6, gives tetrathioethylene derivatives in

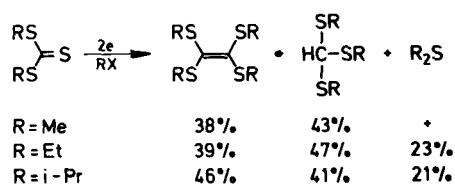

Scheme 6

moderately good yields.²¹ Similarly, alkyl aryl derivatives yield tetraalkylthioethylenes upon cathodic reduction in DMF (Scheme 7).

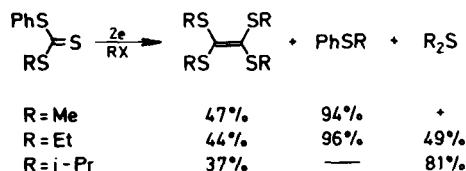

Scheme 7

Providing that Scheme 5 is a reasonably accurate description of the mechanism of decomposition of the anion radicals of the cyclic trithiocarbonates, it seems reasonable to suggest that the difference in behavior as compared to the open chain systems is due to the facile loss of ethylene from the former.

Reduction of diaryl trithiocarbonates followed by alkylation with suitable alkyl halides led to the formation of dialkyl diaryl tetrathioethylenes in low to moderate yields.²² The stereochemistry of the products appears to be governed by the relative bulk of the aryl and alkyl groups with the E isomers predominating (Scheme 8). That no tetraaryl

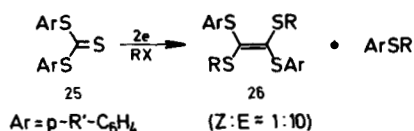

Scheme 8

R' = OMe	7-12%	85-90%
R' = Me	15-26%	70-80%
R' = H	23-41%	55-72%
R' = Cl	40-62%	34-35%
R' = MeCO	6-8%	57-90%

tetrathioethylenes were observed is most likely a consequence of the better leaving group characteristics of the aryl thiolates.

Compounds (27), (29) and (32) are available *via* carbon disulfide reduction. The three classes of compounds were examined as precursors to tetrathioethylenes.¹¹ The reduction of (27) followed by alkylation gave low to moderate yields of the tetrathioethylenes (28),

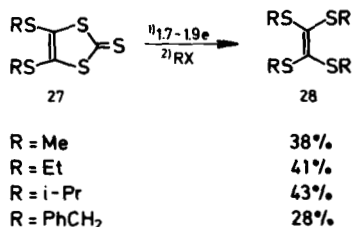

Scheme 9

Scheme 9. On the other hand, the dithiocarbonates (29) gave excellent yields of the corresponding tetrathioethylenes (31) when subjected to the same procedure (Scheme

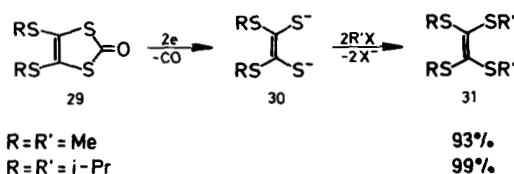

Scheme 10

10). It was found that the reduction of 1,3,4,6-tetrathiapentalene-2,5-dione (32) provides (29) in excellent yield (Scheme 11).

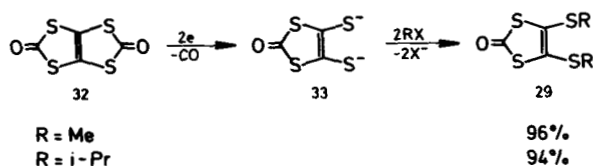

Scheme 11

4. The Electron Transfer Reaction.

Thio-, dithio-, and trithiocarbonates were studied using electroanalytical techniques from a more theoretical point of view.²³ The electrode potentials for the reduction of diaryl trithiocarbonates were observed to give linear Hammett plots when plotted vs. appropriate σ constants for the para substituted derivatives. It should be pointed out that the reversible potentials reported were obtained by an extrapolation procedure rather than by direct measurement. It was found that the cleavage rates for the anion radicals of the same structure also gave a linear Hammett correlation. It was concluded that the cleavage rate is greatest for the most difficulty reduced compounds. For the thio- and dithiocarbonate anion radicals, the dependence of cleavage rate on reversible potential was more complicated and rules were formulated to explain the results. Hammett plots using heterogeneous charge transfer rate constants were not as linear as those for the electrode potentials and cleavage rates. It was proposed that the relationship was a curved one and that it could be explained by electron transfer theory. The Hammett plots for the electrode potentials and the heterogeneous charge transfer rate constants are shown in Figures 7 and 8, respectively. It should be kept in mind that the precision in electrode potential measurements is expected to be considerably greater than that for the heterogeneous charge transfer rate constants. The authors are not convinced that the

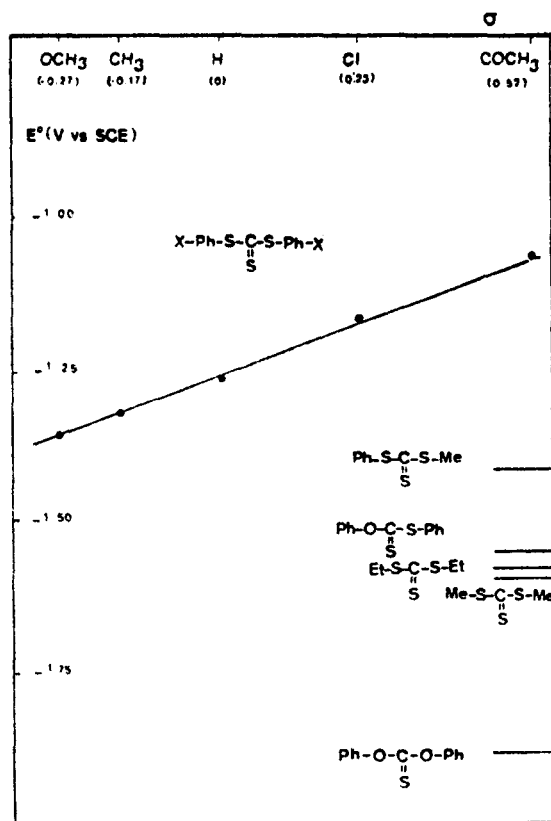

FIGURE 7 Hammett plot of the standard potentials for the reduction of diaryl trithiocarbonates in DMF. (Reprinted from Ref. 23 by courtesy of EDI, France).

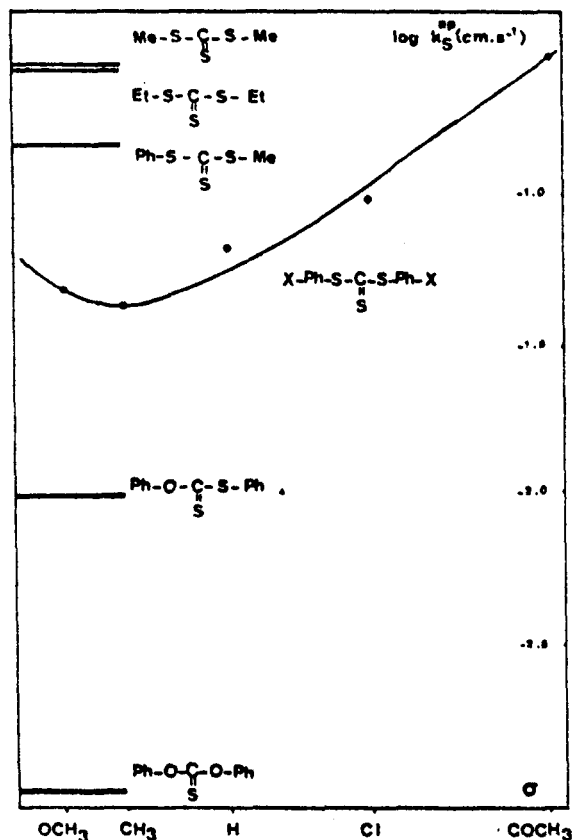
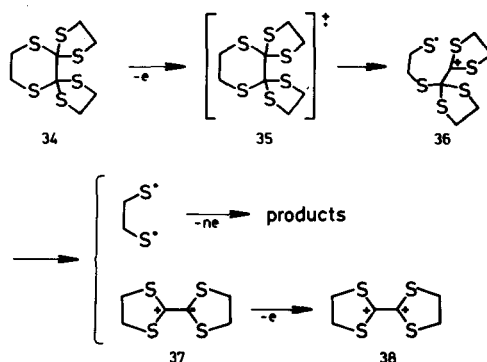

FIGURE 8 Hammett plot of the electron transfer rate constants for diaryl trithiocarbonates in DMF. (Reprinted from Ref. 23 by courtesy of EDI, France).

deviation of the point for the methoxy substituted compound in Figure 8 is of sufficient significance to justify the theoretical conclusions arrived at.²³

V. THIOOXALATES

The cyclic voltammogram obtained for the oxidation of the orthothiooxalate (34) (Scheme 12) in AN indicated the formation of a product which could be reduced in two



Scheme 12

consecutive reversible one electron steps.²⁴ A comparison with the cyclic voltammogram for the oxidation of the tetrathioethylene (39), which consists of two reversible redox couples (Scheme 13), suggested that the product of the oxidation of (34) is the dication

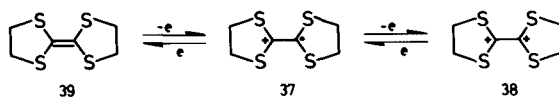

Scheme 13

(38). The identity of the product was supported by the identification of the cation radical (37) from the esr spectrum during the oxidation of (34). The sequence of reactions illustrated in Scheme 12 was proposed to account for the results.

The cyclic voltammogram for the oxidation of (40) indicated a similar but more complex reaction pattern.²⁵ The product of the oxidation was observed to undergo two consecutive reversible one electron reductions. However, the electrode potentials for the reversible couples did not coincide with those expected for the tetrathioethylene produced as in Scheme 12. In this case, a comparison of the voltammogram for the oxidation of the isomeric compound (44) which forms ions (45) and (46), revealed that rearrangement had taken place. Thus, one of the initial products of oxidation was proposed to be (46), formed according to Scheme 14. The cyclic voltammogram giving

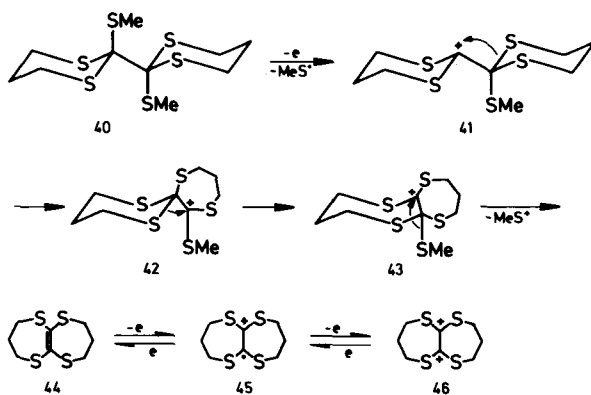

Scheme 14

evidence for the formation of (46) is reproduced in Figure 9. The peaks Ox3 and Ox2 correspond to the formation of (45) and (46) formed by reduction of the ions in the first cycle of the voltammogram.

The dication (46) is not stable and undergoes further rearrangement. Substrates (47) where the alkyl bridges contained either two or three carbons were oxidized under cyclic voltammetric conditions and in both cases reduction peaks could be observed for both the corresponding dications and cation radicals.²⁶ At a voltage sweep rate of 0.1 V/s, rearrangement was effectively complete on the second cycle. The redox behavior can be summarized by the reactions in Scheme 15.

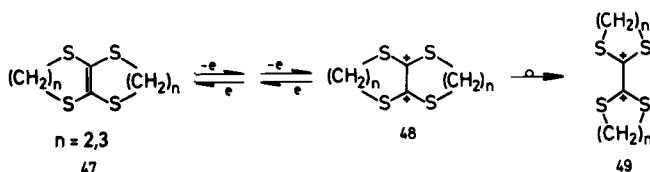

Scheme 15

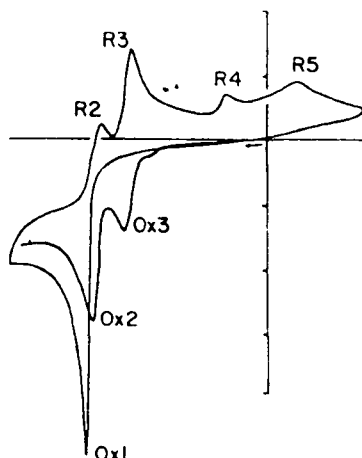
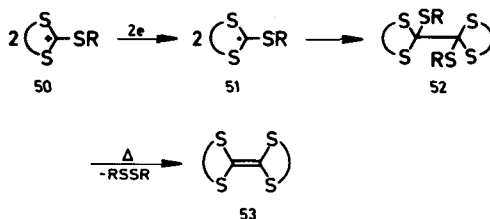

FIGURE 9 Cyclic voltammogram for the oxidation of the *ortho*thiooxalate (40) in acetonitrile. Voltage sweep rate, 130 mV/s. $E_p^{Ox1} = 1.11$ V vs. SCE. (Reprinted from Ref. 25 by courtesy of Elsevier Sequoia S.A.).

VI. SULFUR CONTAINING HETEROCYCLIC CATIONS

1. Trithiocarbenium Ions.

The reduction of trithiocarbenium ions of general structure (50) has been studied as a synthetic route to the formation of tetrathioethylenes.^{19,27-29} In general, cyclic voltammetry at voltage sweep rates up to 100 V/s indicates that reduction is a one electron irreversible process. Analysis of the peak potential dependence on sweep rate and on substrate concentration gave results compatible with a radical-radical dimerization



Scheme 16

mechanism as shown in Scheme 16. The data clearly rule out a mechanism involving coupling of the radical (51) with the substrate (50).

2. 1,3-Dithiolylium Ions.

The heteroaromatic ions of structure (54) are conveniently prepared from (6) by reaction with Meerwein's salt (Scheme 17). Reduction again gives the dimers which undergo thermal elimination of Me_2S_2 accompanied by the generation of the tetrathioethylene (56).²⁸

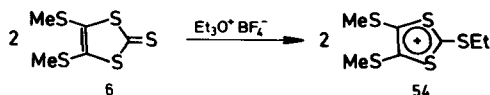

Scheme 17

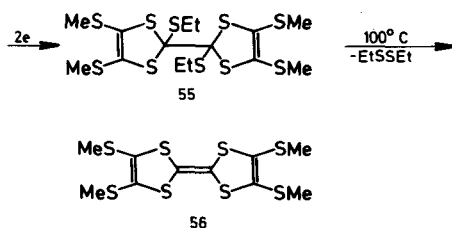
Scheme 17
(continued)

A number of related compounds have been studied, some of which contain selenium (57–62). The behavior of these compounds differ only in that the elimination of R_2Se_2 occurs readily at room temperature.²⁹

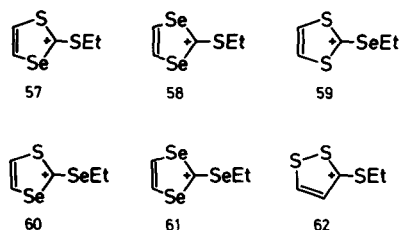

3. 1,2-Dithiolylium Ions

The reduction of 3,4-diaryl-1,2-dithiolylium ions was compared to the comparable reactions of tropylium ions.³⁰ The irreversible reduction gives rise to the cyclic voltammogram (Figure 2) discussed earlier. The reactions are shown in Scheme 18.

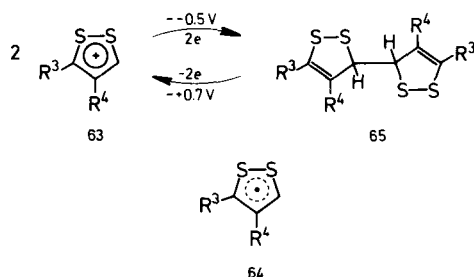

Scheme 18

Reduction of (63) to dimer (65) could be reversed by anodic oxidation without loss of material. The reduction involves most likely the radical (64) as an intermediate.

The cyclic voltammogram for the reduction of 3,5-diphenyl-1,2-dithiolylium ion (66) in AN (Figure 1) indicates that in this case the free radical (67) is stable in solution.³¹ The

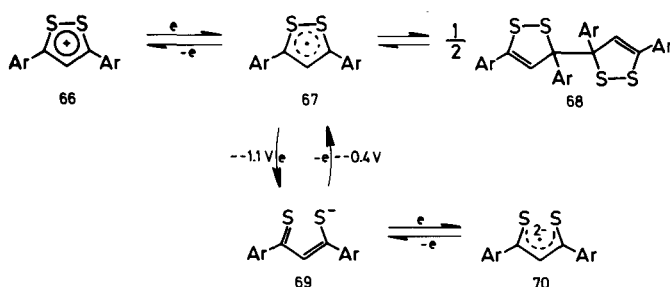

Scheme 19

TABLE I

Estimate of Relative Equilibrium Constants for Dissociation of the Dimer (68) in CH_2Cl_2 at room temp.³²

(Ar, Ar)	(Monomer) ^a $\times 10^{-3} M$	(Dimer) ^a $\times 10^{-3} M$	K_x/K^b
(<i>p</i> -An, <i>p</i> -An)	0.38	0.43	0.06
(<i>p</i> -An, Ph)	0.51	0.37	0.13
(<i>p</i> -An, <i>p</i> -DMAPh)	0.65	0.30	0.26
(<i>p</i> -Tol, <i>p</i> -Tol)	0.80	0.22	0.54
(<i>p</i> -Tol, Ph)	0.81	0.22	0.55
(Ph, Ph)	0.93	0.16	1.0
(<i>p</i> -BrPh, Ph)	0.94	0.15	1.1

^a Estimated from peak currents during voltammetry at 150 mV/sec. Substrate concentration = $1.25 \times 10^{-3} M$.

^b Equilibrium constant for the compound divided by K for Ar = Ph.

stability of (67) was attributed to steric interactions giving rise to a weakening of the bond linking the monomer moieties together in the dimeric structure (68). At low temperature the equilibrium (Scheme 19) favors the dimeric form.

The monomer-dimer equilibria as well as further reduction of the radicals (67) was studied in further detail.³² The equilibrium constants at room temperature were found to be strongly dependent upon the para substituent of the aryl groups of (67). Electron

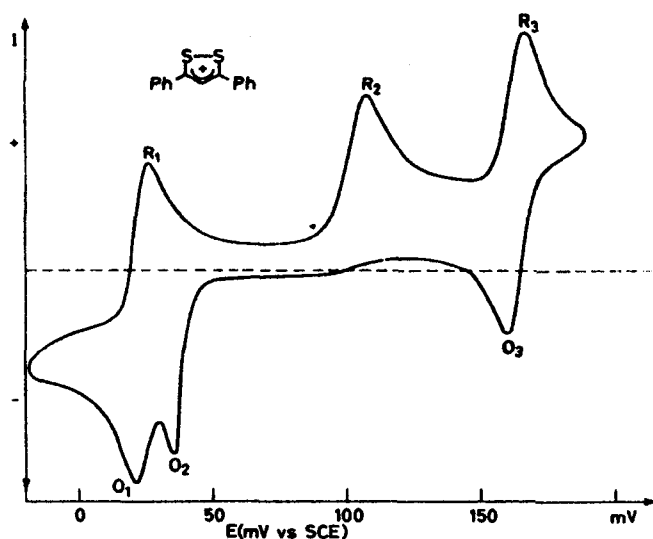

FIGURE 10 Steady state cyclic voltammogram of 3,5-diphenyl-1,2-dithiolium ion in acetonitrile. Voltage sweep rate, 300 mV/s. The voltage scale should be: 0, 500, 1000 and 1500 mV. (Reprinted from Ref. 32 by courtesy of The American Chemical Society).

donating substituents appear to favor the dimers (68). Equilibria data are summarized in Table I.

The irreversible reduction of (67), accompanied by ring cleavage to (69), is demonstrated by the cyclic voltammogram (R_2) in Figure 10. It is of interest to note that the ring opening reaction can apparently be reversed by oxidation at O_2 . The anion undergoes reversible reduction (R_3) to the dianion radical (70).

4. Thiopyrylium Ions

The bithiopyrylium ions (71) were observed to undergo two consecutive reversible one electron reductions to the cation radicals (72) and the neutral substances (73) as

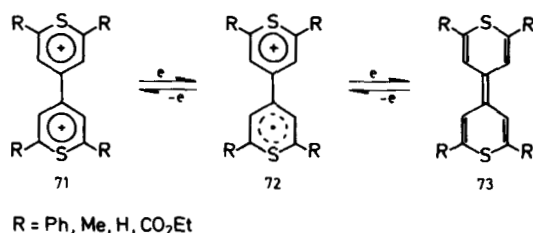

Scheme 20

illustrated in Scheme 20.³³ Similarly, oxidation of substances (74) resulted in the formation of the cation radicals and dication, sometimes reversibly (Scheme 21).³⁴

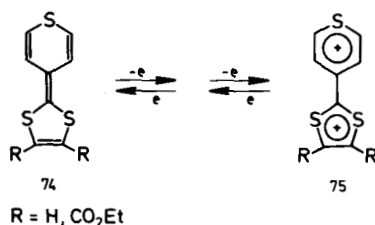

Scheme 21

Kissinger, Holt and Reilly³⁵ have carried out a very thorough study on the reactions of the thiopyrylium ion (77) generated by anodic oxidation of (76). The pyrylium ion (77)

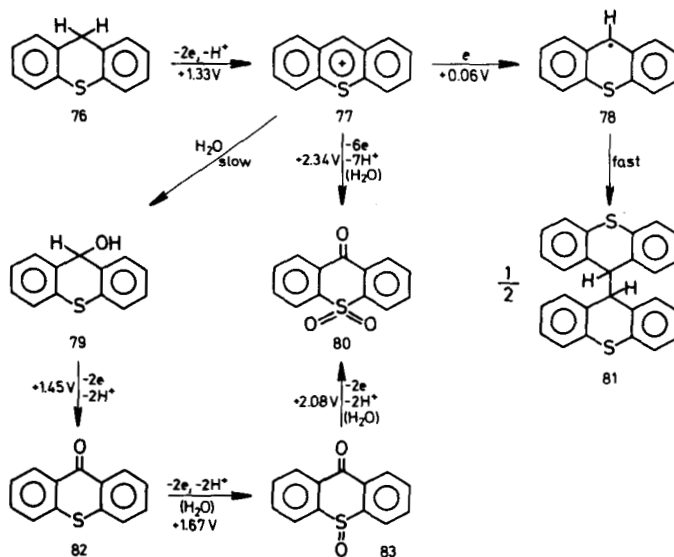

Scheme 22

was observed to be stable in acetonitrile but reacted slowly with water to give (79) which could be oxidized first to (82) and then to (83) and finally to (80). The fully oxidized product (80) could also be obtained by the direct oxidation of the pyrylium ion in wet acetonitrile. The reactions are summarized in Scheme 22. Current reversal chronopotentiometry³⁶ was used to demonstrate the quantitative formation of (77) during oxidation of (76) and the process was compared to the analogous process, the oxidation of tropyliidene to tropylium ion.³⁷ The excellent fit of the experimental to theoretical data for the ECE type reaction is illustrated in Table II. The reduction of (77) to radical (78) which dimerizes to (81) was also demonstrated by chronopotentiometry. Oxidation of dimer (81) was found to regenerate (77). Deprotonation of the postulated reaction intermediate (84) could not be detected (Scheme 23). The dimer (81) was also prepared by reduction of the bipyrylium ion (86) first to (85) in a reversible reaction before the final step.

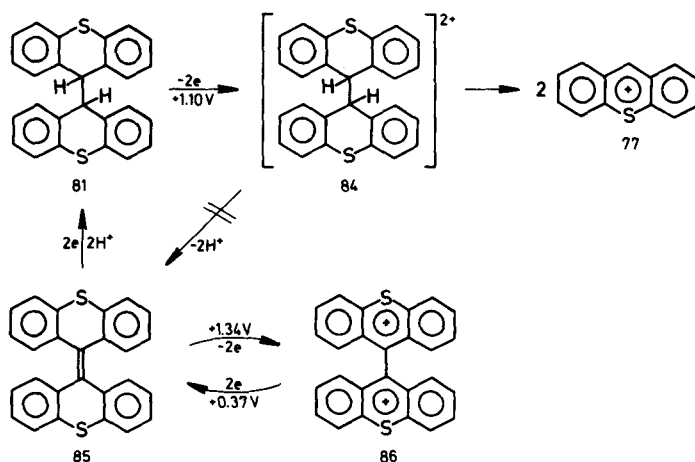

Scheme 23

VII. TETRATHIOETHYLENES

The effect of structure on the reversible oxidation potentials to generate the cation radicals and dications of the tetrathioethylenes (87) to (90) gives a clear indication of the role of conjugation in stabilizing the ions.³⁸ The reversible potentials for both oxidation

TABLE II

Transition Time Ratios for the Mechanism:³⁵

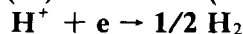
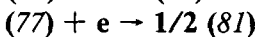
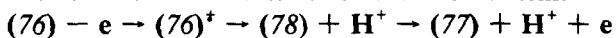

Ratio	Theoretical Value ^a	(76)
t_f/τ_b	8	8.1
τ_c/τ_b	1.66	1.7
$t_f/(\tau_b + \tau_c)$	3	3.02

^aR. M. King and C. N. Reilley, *J. Electroanal. Chem.*, **1**, 434 (1960). t_f is the forward transition time and τ_b and τ_c are the transition times for the two reduction reactions.⁷

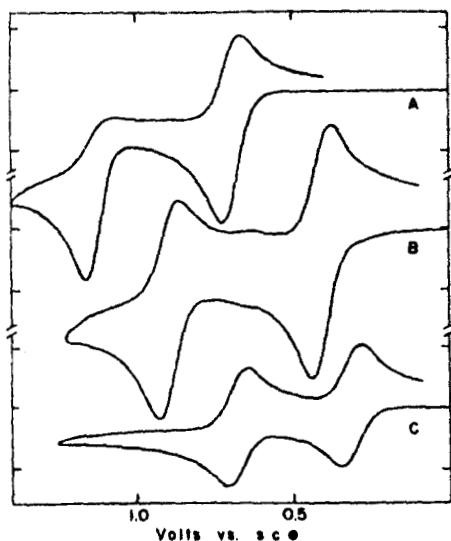
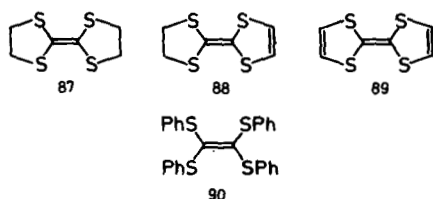
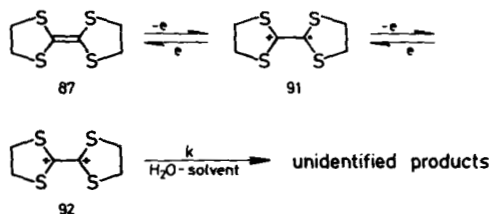

FIGURE 11 Cyclic voltammograms of (A) (87), (B) (88) and (C) (89) in acetonitrile. Sweep rates, (A) 24 mV/s, (B) 120 mV/s and (C) 120 mV/s. (Reprinted from Ref. 38 by courtesy of The American Chemical Society).

stages in case of (87), (88) and (89) are progressively lower as the conjugation increases. Furthermore, the kinetic stability of the corresponding dications is increased in the same



way. The latter is demonstrated by the cyclic voltammograms illustrated in Figure 11. In A very little recovery of the dication is observed after the sweep is extended beyond the second oxidation stage. The voltammogram for (88), B, shows that the dication is reacting but at a lower rate. No apparent reaction can be detected for the dication of (89) in C. The voltammetry is summarized by the reactions shown in Scheme 24. It is interesting to



Scheme 24

note that dication (92) is formed reversibly during cyclic voltammetry experiments in $\text{AlCl}_3\text{-NaCl}$ mixtures.³⁹ This suggests that the reason behind the apparent reactivity in AN is due to the failure to completely remove water from the solvent-electrolyte system.

With regard to the effect of structure on the ease of formation of the tetrathioethylene cations, the oxidation of the open chain derivative (90) is of special interest. The cyclic

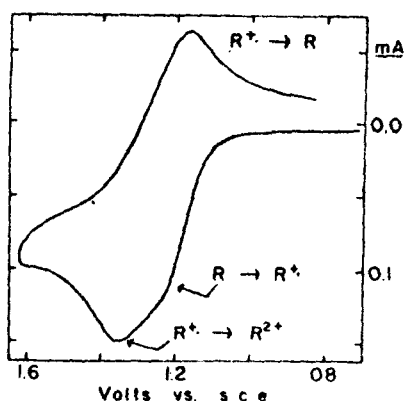
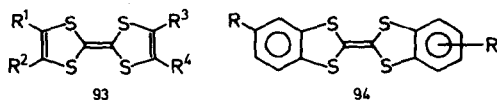

FIGURE 12 Cyclic voltammogram for oxidation of (90) in acetonitrile. Voltage sweep rate, 300 mV/s. (Reprinted from Ref. 38 by courtesy of The American Chemical Society).

voltammogram illustrated in Figure 12 indicates that the two oxidation stages are so closely separated that cation radical and dication formation appear as an overlapped peak. The peak potential is about 0.5 V more positive than that for the most difficulty oxidized cyclic system (87). The observed oxidation potential compares very favorably to data previously reported for the oxidation in AN and nitromethane at rotating electrodes.⁴⁰ The dication in this case appears to be very reactive and only the cation radical reduction can be observed on the reverse scan. It would be of interest to have data on this compound under conditions where the dication reduction could be observed. The fact that the open chain cation radical is formed at a much higher potential than the corresponding cyclic systems is probably a consequence of destabilization of the neutral compounds with cyclic structures due to steric interactions between the two ring systems. The latter point was not discussed in the original work.³⁸

A number of studies have been devoted to the measurement of reversible potentials for the oxidation of tetrathioethylenes.⁴¹⁻⁴⁵ Reference to the original literature for the various structures (93) and (94) will only be given here; monosubstituted (93) with methyl and ethoxycarbonyl,⁴⁴ alkyl substituted (93),⁴³ unsubstituted and methyl substituted (94),⁴¹⁻⁴² monophenyl (93) and some more exotic structures.⁴⁵



An unusual reaction has been postulated during the oxidation of the carboxylate (95). When the cyclic voltammogram was recorded in AN in the presence of Na^+ , the cation radical salt (97) precipitated on the electrode.⁴⁶ When the oxidation was carried out at a potential where the dication (98) is formed, a slow evolution of CO_2 occurred and the tetrathioethylene dication (100) could be detected. The reactions in Scheme 25 were proposed to account for the results. The key step is the decarboxylation of dication (98) to the ionic species (99) which was then supposed to abstract protons from the medium to generate (100). In the presence of (100) the precipitated salt (97) dissolved and was oxidized to (98), while oxidation of (101) at the electrode regenerated (100). The reason for decarboxylation is obscure. Structure (99) would appear to be of higher energy than (98). A scheme involving the decarboxylation of (96) would appear to be much more

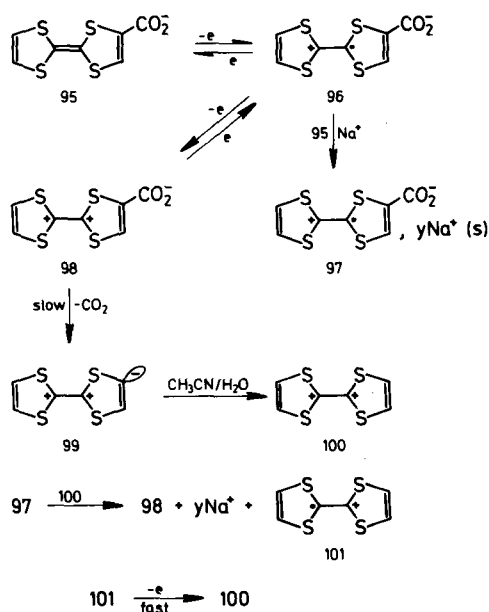

Scheme 25

reasonable. Perhaps the function of (100) is to complex with (96) and prevent the precipitation of (97).

Tetrathiafulvalene cation radical salts can be prepared by the oxidation of (89) in the presence of bromide ion.⁴⁷ Similarly, tetracyanoethylene charge transfer complexes of (89) could be grown as crystals on an electrode surface.⁴⁸ The tetrathiafulvalene-tetracyanoquinodimethane charge transfer complex has also been compressed into pellets and tested as a semi-conductor electrode.⁴⁹

VIII. THIOCARBOXYLATES AND THIOESTERS

1. Thiocarboxylates.

In general, thiocarboxylate salts undergo anodic oxidation to the corresponding disulfides. The reactions can be reversed by cathodic reduction of the disulfides as indicated in Scheme 26.⁵⁰⁻⁵³

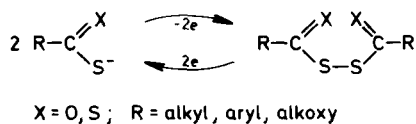

Scheme 26

The anodic oxidation of (102) has been reported to result in the formation of substances containing the tetrathiane ring system.⁵³ The cyclic voltammogram for the oxidation of (103), obtained by anodic oxidation of (102), is shown in Figure 13. The reactions summarized by Scheme 27 were suggested on the basis of this voltammogram. Oxidation peak P₁ was postulated to be due to oxidation of (103) to the cation radical (104) which is in equilibrium with the cyclic form (107) which is oxidized along with (104) at P₂ to produce the dication (105) and the cyclic isomer (106), the reduction of which

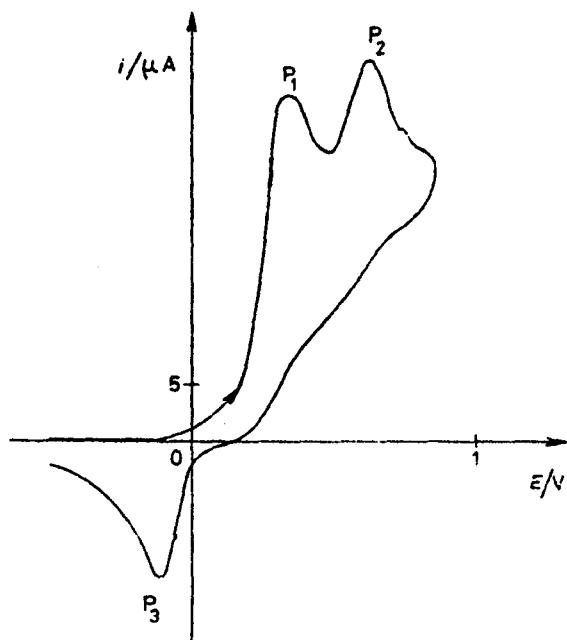
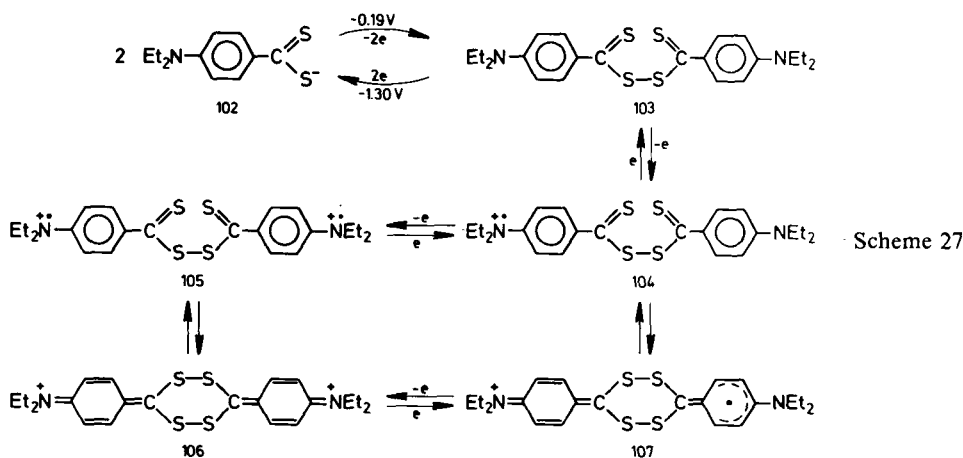

FIGURE 13 Cyclic voltammogram of (103) in acetonitrile. Voltage sweep rate, 80 mV/s. (Reprinted from Ref. 53 by courtesy of The Royal Society of Chemistry).



appear at P_3 . While, the voltammogram can be rationalized in this manner, numerous other possibilities can be visualized which could give this rather indescriptive voltammetry.

2. Thioesters.

Extensive polarographic measurements have been made on thioesters of general structures (108), (109) and (110).⁵⁴⁻⁵⁸ Preparative studies were carried out on esters (111)

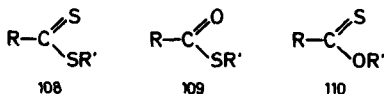

and (114).⁵⁴ In both cases, polymers were formed and methyl mercaptan could be identified from the reaction mixtures. The reactions are summarized in Scheme 28.

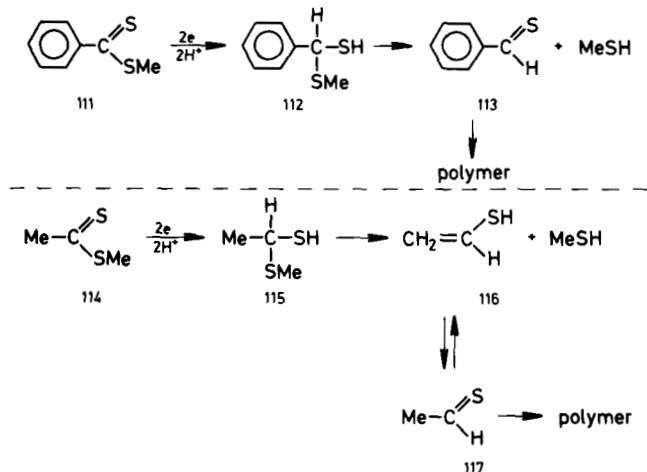

The effect of structure on the half-wave potentials of compounds (118)–(121) is indicated by the values given below the structures. The potentials become less positive by about 0.3 V with each change in going from (118) to (119) to (120) to (121). Thus, the

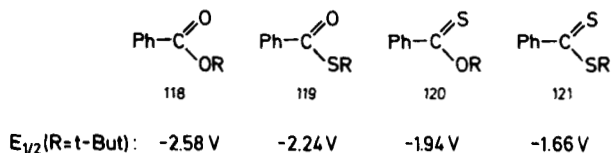

change of S to O in the single-bonded group results in a 0.3 V change in potential while the same change in the double bonded group brings about a change of about 0.6 V.⁵⁸ A similar set of potentials were found when $\text{R}=\text{Me}$.⁵⁴ For a series of (108) where R is parasubstituted phenyl, the polarographic half-wave potentials in DMF gave an excellent correlation with Hammett sigma values. It is remarkable that the correlation encompassed substituents varying from $-\text{NO}_2$ to $-\text{NMe}_2$ with essentially no deviations from the linear relationship.⁵⁴

A detailed product study was carried out on the reactions of esters (121) and (119).⁵⁹ The products and yields for the reactions of the various derivatives are summarized in Scheme 29. The cyclic voltammogram shown in Figure 14 gives further indication of the course of the reaction. The initial reduction peak corresponds to the reduction and

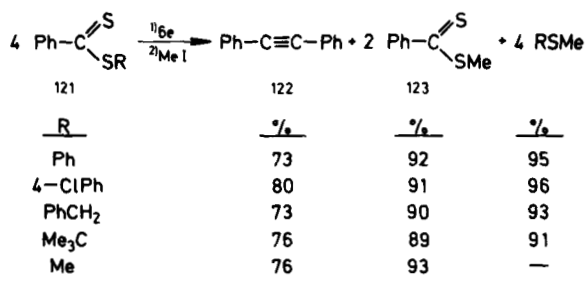

Scheme 29

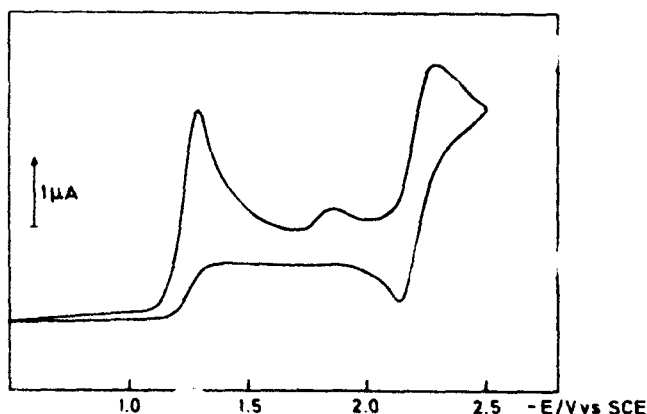
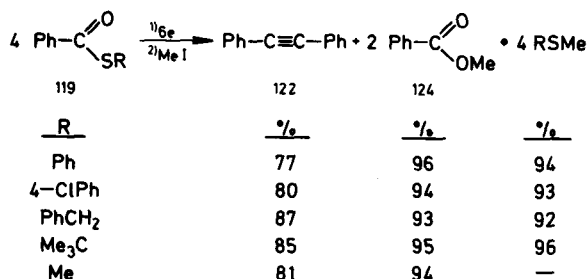

FIGURE 14 Cyclic voltammogram of (121) ($R = \text{PhCH}_2$) in DMF. Voltage sweep rate, 800 mV/s. $c = 1.83$ mM. (Reprinted from Ref. 59 by courtesy of Acta Chemica Scandinavica).



Scheme 29
(continued)

further reaction of substrate. The second small peak is due to the formation of the dianion while the third reversible couple is due to diphenylacetylene and the corresponding anion radical. Upon increasing the voltage sweep rate the effect of the reactions following charge transfer was diminished to the point that the second peak has the characteristics of a one electron irreversible reduction. Under the latter conditions, the peak separation for the quasi-reversible reduction of substrate indicates a relatively slow heterogeneous charge transfer.

A detailed scheme was proposed to account for the formation for products (122) and (123). It should be kept in mind that while this sequence of reactions appears to be reasonable, the existence of the various intermediates is highly speculative (Scheme 30).

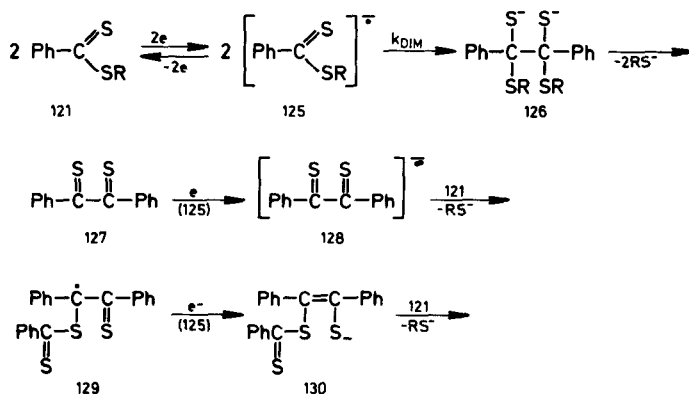

Scheme 30

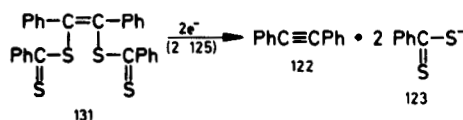
Scheme 30
(continued)

An electrochemically induced rearrangement of S,S-diarylbenzene-1,2-dicarbothioates has been reported.⁶⁰ The reduction of (132) produced (137) in high yield. The essential features of the mechanism proposed are summarized in Scheme 31. The cleavage of the

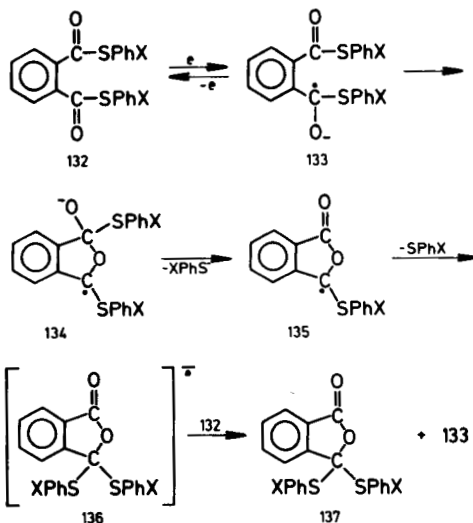

Scheme 31

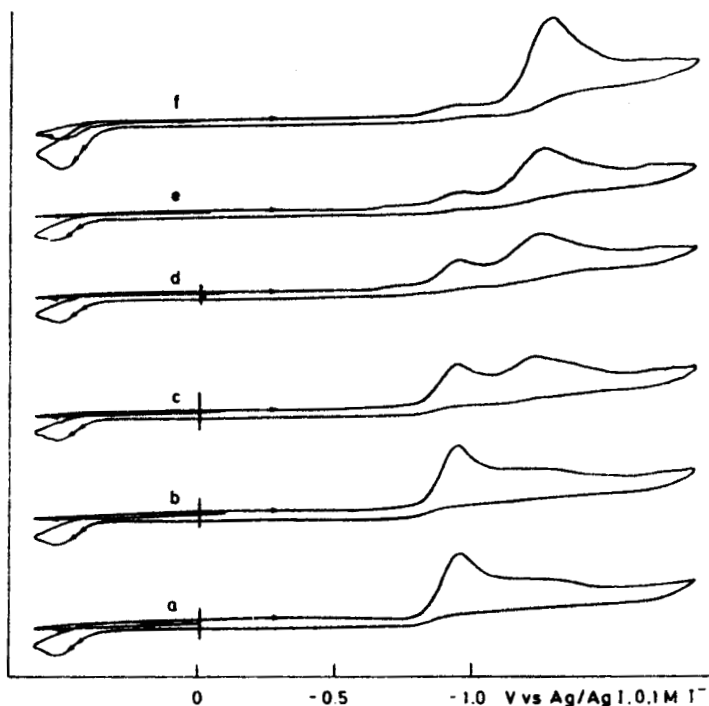

FIGURE 15 Cyclic voltammogram of (132) (X = H) in DMF before (a) and immediately after (b) electrolytic reduction (0.05 F/mol). (c) 30 min after, (d) 1 h after and (e) 2 h after. (f) illustrates the cyclic voltammogram of solution (e) after addition of (137) (X = H). (Reprinted from Ref. 60 by courtesy of Acta Chemica Scandinavica).

radical anion (134) to the radical (135) and subsequent recombination to (136) can be viewed as an $S_{RN}1$ type of reaction. The reaction was observed to proceed to completion after the passage of only catalytic amounts of current. This behavior is demonstrated by the cyclic voltammograms reproduced in Figure 15. Scan a was recorded immediately after a short electrolysis. The first peak corresponds to the reduction of substrate and the small second peak is due to the product. Scan b-e were recorded at increasing time intervals. The voltammograms clearly show the growth of the peak due to the reduction of the product at the expense of that due to the substrate. Scan e, where reaction is nearly complete was recorded two hours after the electrolysis was terminated. Scan f was due to the same solution as that for scan e but the product was added, showing an increase in the peak height for the product but no other changes.

IX. 1,2-DITHIOLE-3-THIONES AND RELATED COMPOUNDS

1. 1,2-Dithiole-3-thiones.

The oxidation of a series of compounds (138) were studied under cyclic voltammetric and preparative conditions.⁶¹ In all cases the dimeric dication bonded through S-S bonds were the products (139). After oxidation the substrates could be regenerated in yields ranging from 100 to 60% by cathodic reduction.⁶¹ The reactions involved are summarized in Scheme 32.

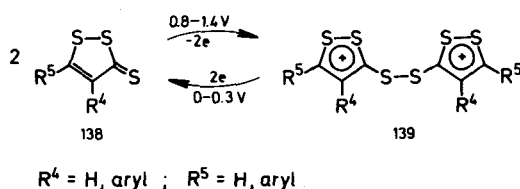

Scheme 32

Reduction of (140) was observed to produce (143) which could be identified as the methyl derivative after alkylation with methyl iodide.⁶² The failure to observe an esr signal after one electron reduction led to the proposal that the dimer-radical (141) equilibrium favors the dimeric form believed to be bonded through either the 3 or 5 positions. The data were rationalized in terms of the reactions shown in Scheme 33. This

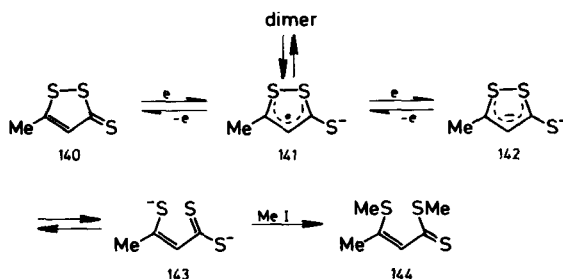

Scheme 33

reaction sequence was later observed to be a very good synthetic procedure for the preparation of compounds (146) by reduction of (145) as indicated in Scheme 34.⁶³

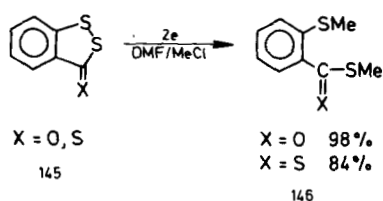

Scheme 34

2. α -(1',2'-Dithiol-3'-ylidene)acetophenones.

The title compounds (*147*) formed dimeric dications upon anodic oxidation in AN.⁶⁴ The dications (*148*) undergo slow deprotonation to (*149*) which were isolated in moderate yields. The dimers (*148*) could also be dehydrogenated chemically with DDQ to form the series of dications (*150*). The reactions involved in the various transformations are summarized in Scheme 35. The oxidation of (*147*) and the reduction of the dimer (*148*) is

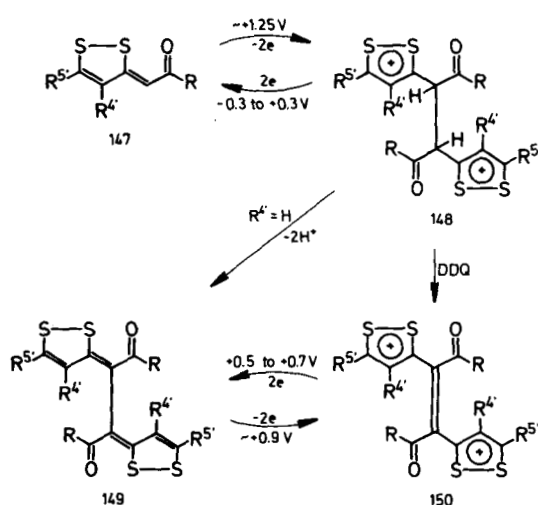

Scheme 35

demonstrated by the cyclic voltammogram shown in Figure 16, where the peaks labelled O_1 and R_2 refer to the two processes, respectively. Figure 17 is typical of the

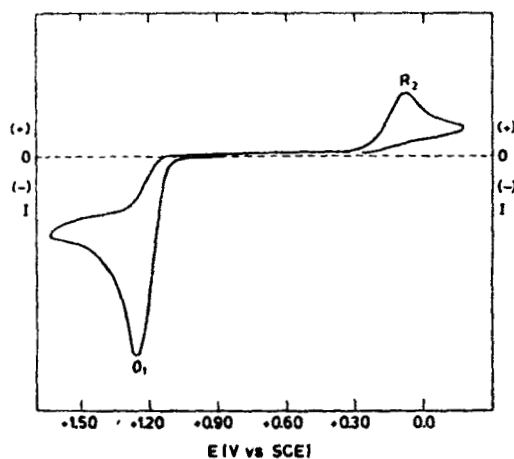

FIGURE 16 Cyclic voltammogram of (*147*) ($R = R^{4'} = R^{5'} = \text{Ph}$) in acetonitrile/dichloromethane (1/1). Voltage sweep rate, 86 mV/s. (Reprinted from Ref. 64 by courtesy of Acta Chemica Scandinavica).

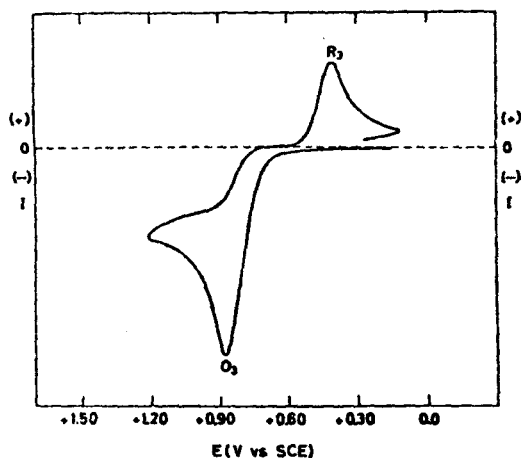
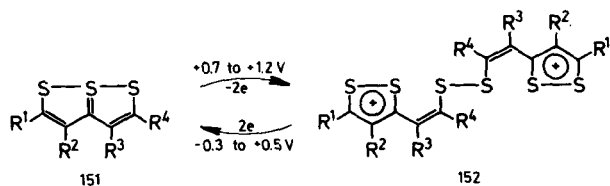

FIGURE 17 Cyclic voltammogram of (149) ($R = R^4 = R^5 = \text{Ph}$) in dichloromethane. Voltage sweep rate, 86 mV/s. (Reprinted from Ref. 64 by courtesy of Acta Chemica Scandinavica).

voltammograms observed for the dehydro dimers (150). In this case the separation of O_3 and R_3 is not due to the intervention of chemical reactions but rather to conformational differences in the neutral and cationic species. Such large conformation changes is in general accompanied by apparently slow heterogeneous charge transfer. Analogous behavior was reported during the reduction of (86) to (85).⁵³

3. 1,6,6a λ^4 -Trithiapentalenes.

Redox potentials were reported for a series of (151) and (152) undergoing the anodic dimerization-cathodic cleavage reactions illustrated in Scheme 36. Starting with neutral



Scheme 36

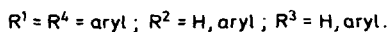

(151) the dimeric dications (152) could be obtained in essentially quantitative yield and reduction resulted in the recovery of the substrates in 84–100% yield.⁶⁵

A similar series of compounds (153) were reduced at -60°C in DMF.⁶⁶ ESR spectra were

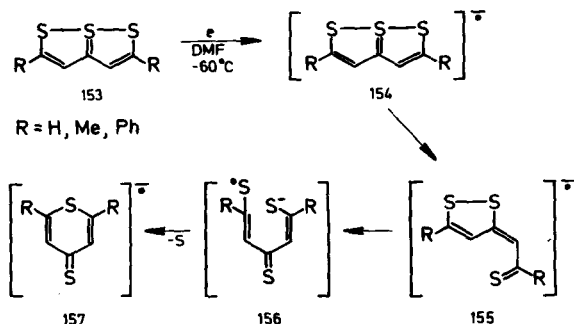

Scheme 37

used to establish the existence of both the primary products of electron transfer (154) and the rearranged anion radicals (157) believed to form *via* Scheme 37.

X. 1,4-DITHIINS AND BENZODERIVATIVES

1. 1,4-Dithiins and 2,3-Benzo-1,4-dithiin.

The fusion of benzene rings to the dithiin ring brings about an increase in the oxidation potential.⁶⁷ The increasing trend in going from (160) to (159) to (158) can be rationalized

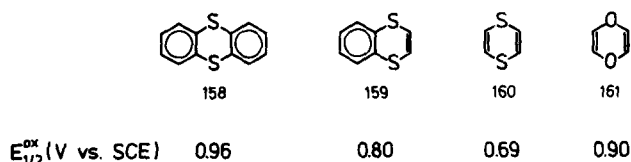

in terms of a decrease in electron density in the dithiin ring with the changes in bond order. Likewise, the increase in $E_{1/2}^{ox}$ in going from (160) to (161) reflects the fact that the non-bonding electrons on the heteroatom are held more tightly by the more electronegative element.

An apparent anomaly exists in the kinetic and thermodynamic stabilities of the series of para-substituted diaryldithiins (162).⁶⁸ The peak potentials during cyclic voltammetry for

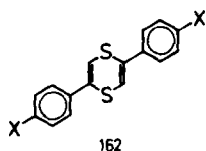

X = MeO, H, Cl, Br, NO₂

the oxidation of (162) were found to vary in the order, $p\text{-NO}_2 > \text{Br} \sim \text{Cl} > \text{H} > \text{MeO}$ and the lifetimes of the resulting cation radicals were unexpectedly found to fall into the same order. The reason for this unusual trend in reactivities was attributed to the fact that it is the radical character rather than the cation character of the ion radicals that determines the reactivity. Those substituents which bring about an increase in the odd electron density in the aryl groups hinder the dimerization of the cation radicals.

A kinetic investigation showed that two major reaction pathways are involved in the dimer forming reactions of the cation radicals of (162).⁶⁸ At substrate concentrations of the order of 1 mM, the kinetics suggest a mechanism involving the coupling between a radical cation and the substrate. At higher ion concentrations simple dimerization of the cation radicals is apparently a competing reaction.

2. Thianthrenes and Related Compounds.

The anodic oxidation of thianthrene and related compounds as well as the reactions of the corresponding cation radicals has received a great deal of attention.⁶⁹⁻⁸⁷ An early study demonstrated that the oxidation of (158) generated the cation radical which was identi-

fied from the ESR spectrum.⁶⁹ Voltammetric studies were carried out on the oxidation of thianthrene as well as compounds (163) to (170) and in many cases the ESR spectra of the

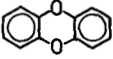
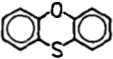
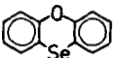
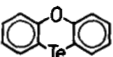
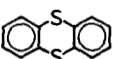
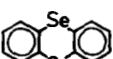
	$E_{1/2}^{ox}$ (V vs. Ag/Ag ⁺)
	0.991
163	
	0.825
164	
	0.751
165	
	0.366
166	
	0.865
158	
	0.832
167	

cation radicals were obtained.⁷⁰⁻⁷² The same trends in ease of oxidation, *i.e.* the more electronegative the heteroatom the higher the oxidation potential, as was observed for (160)–(161) are evident from the data for (158), (163)–(167).⁷⁰ It is of special interest to note that

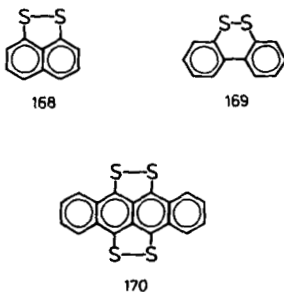

(168) undergoes reversible reduction as well and the ESR spectra of both the anion radical and the cation radical were obtained.⁷¹

The reactions of thianthrene cation radical with nucleophiles has been the subject of much discussion and some controversy. The cation radical reacts with water to give thianthrene-5-oxide (171).⁷³ Oxidation of (158) in 80% (v/v) HOAc/H₂O containing HClO₄ gave (171) in quantitative yield when the reaction was carried out at +1.1 V vs. Ag/AgCl (Scheme 38).⁷⁴ At an anode potential of +1.6 V a complex reaction mixture

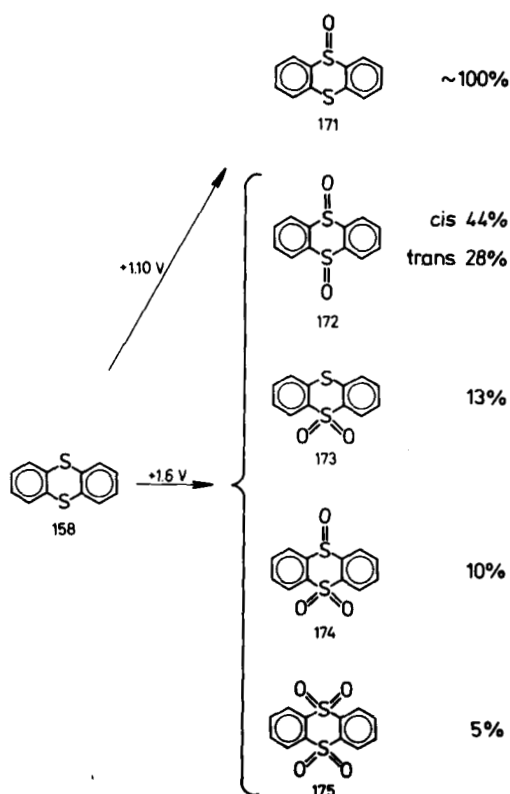

containing (172)–(175) was obtained. The same products were obtained by oxidation of (171).⁷⁴

A kinetic study of the reaction of (176) with water indicated that the reaction is second order in cation radical (Scheme 39) and the rate was found to be inversely proportional to

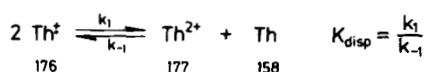

Scheme 39

$$-\frac{d[\text{Th}^{\cdot+}]}{dt} = k_2 K_{\text{disp}} \frac{[\text{Th}^{\cdot+}]^2 [\text{H}_2\text{O}]}{[\text{Th}]}$$

the concentration of (158).⁷⁵ These observations led to the suggestion that reaction involves disproportionation and that the dication is the reactive species. The disproportionation mechanism was challenged on the basis of potential step-sweep voltammetry experiments and it was concluded that the cation radical is the species reacting with water.⁷⁶ A possible reaction sequence (Scheme 40) which accounts for the data was proposed. In order for this scheme to account for the kinetics the deprotonation of (179) would have to contribute to determining the rate of the reaction.

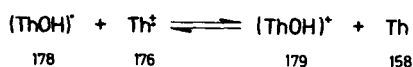
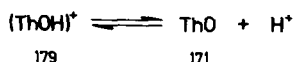

Scheme 40

Scheme 40
(continued)

In order to evaluate the feasibility of the disproportionation mechanism, it is necessary to estimate the equilibrium constant, K_{disp} . The pertinent data necessary are the potentials for the formation of the cation radical and the dication (Scheme 41). The reversible poten-

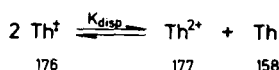
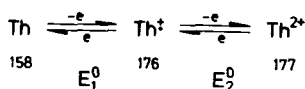

Scheme 41

$$K_{\text{disp}} = 10^{\frac{-1(E_2^0 - E_1^0)}{0.059}}$$

tial for the formation of the cation radical of thianthrene is readily determined by cyclic voltammetry. However, the dication (*177*) is very much more reactive and only irreversible cyclic voltammograms for the oxidation of (*176*) were observed during voltammetric studies.

A derivative of thianthrene (*180*) by virtue of the stabilizing influence of the methoxy groups was observed to form a relatively stable dication.⁷⁷ The electrode potential differ-

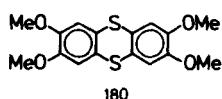

ence for the reversible formation of the cation radical and the dication was observed to be 250 mV in this case in acetonitrile indicating a K_{disp} of the order of 10^{-4} . It is of further interest that the dication of (*180*) was observed to be a ground state triplet in spite of the fact that HMO calculations do not predict this.⁷⁸

The relatively large K_{disp} observed for the cation radical of (*180*) suggests that disproportionation reactions are feasible in the thianthrene cation radical series providing that methoxy substitution was not the cause of the small difference in the reversible potentials for the successive oxidations of (*180*). However, even the irreversible cyclic voltammograms for the oxidation of thianthrene cation radical indicated that K_{disp} is much smaller in the unsubstituted case.

It was found that the effective removal or passivation of nucleophiles in the voltammetric solutions made possible the measurement of the reversible potential for the oxidation of (*176*) and other cation radicals producing reactive dications.⁷⁹ A number of different methods have been used to accomplish the latter. The most pertinent of these is the use of neutral alumina to scavenge impurities in the solvent electrolyte system.⁷⁹ Other methods include deactivating nucleophilic impurities with strong mineral acid in trifluoroacetic acid,⁸⁰ or with trifluoroacetic anhydride,^{79,81} or the use of cation stabilizing solvents such as trifluoroacetic acid⁸² or sulfur dioxide.⁸³

TABLE III

Calculated disproportionation equilibrium constants for Th^+ in different solvents.⁷⁹

Solvent	$\Delta E(\text{V})$	$K_{\text{disp}}(10^{12})$
CH_3CN	0.51	2300
$\text{C}_2\text{H}_5\text{CN}$	0.46	16000
$(\text{CH}_3)_2\text{CHCN}$	0.42	76000
$\text{C}_6\text{H}_5\text{CN}$	0.49	4900
CH_3NO_2	0.53	1000
$\text{C}_6\text{H}_5\text{NO}_2$	0.51	2300
CH_2Cl_2	0.50	3300
A*	0.60	68
B†	0.69	2

* Solvent system A; CH_2Cl_2 -TFA-TFAn (45/1/5).

† Solvent system B; TFA-TFAn (9/1).

The value of K_{disp} for thianthrene cation radical is very dependent upon the solvent. Values ranging from 10^{-7} to 10^{-13} have been found. Values obtained in a variety of solvents are summarized in Table III. The access to reliable values of K_{disp} provides a basis for the discussion of possible disproportionation mechanisms.

In Scheme 41, if k_{-1} is assumed to be a diffusion controlled rate constant ($\sim 10^{10} \text{ M}^{-1} \text{ s}^{-1}$), the maximum possible value of k_1 can be estimated using experimentally determined K_{disp} values. For example, in acetonitrile this leads to a value of $23 \text{ M}^{-1} \text{ s}^{-1}$ as the maximum possible value of an observed rate constant for a reaction of (176) following the disproportionation mechanism. If the disproportionation is considered to be in equilibrium, $k_1[\text{Th}^+]$ must be at least $10 \cdot k_2[\text{Th}^{2+}][\text{H}_2\text{O}]$ and the value of the apparent second order rate constant could not exceed $2.3 \text{ M}^{-1} \text{ s}^{-1}$. On the basis of this analysis and the data reported in support of the disproportionation mechanism⁷⁵ we arrived at the conclusion that Scheme 41 represents a feasible mechanism for the hydroxylation of (176). However, more detailed kinetic studies in acetonitrile⁸⁴ and dichloromethane-trifluoroacetic acid⁸⁵ resulted in the rate laws given in Scheme 42, neither of which are

$$-\frac{d[\text{Th}^+]}{dt} = \frac{2kK_1^2K_2[\text{Th}^+]^2[\text{H}_2\text{O}]^3}{[\text{H}_3\text{O}^+]} \quad (\text{acetonitrile, ref. 84})$$

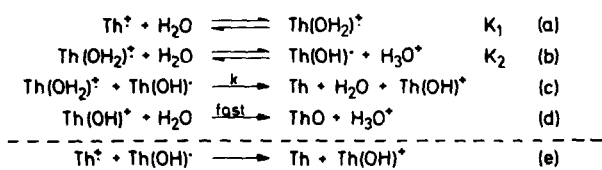

Scheme 42

$$-\frac{d[\text{Th}^+]}{dt} = \frac{0.32[\text{Th}^+]^2[\text{H}_2\text{O}]}{([\text{Th}] + 8.8 \cdot 10^{-4})[\text{TFA}]^2} \quad (\text{CH}_2\text{Cl}_2/\text{TFA, ref. 85})$$

consistent with the disproportionation mechanism. Since the two rate laws differ significantly, the mechanisms in the two solvents differ in some respects.

Before discussing the hydroxylation mechanism it is instructive to examine the electrophilic reactions of thianthrene cation radical with anisole⁸⁶ and phenol,⁸⁷ the mechanisms of which appear to be more firmly established.^{88,89} The observed kinetics require that the initial step in the reaction (Scheme 43) between (176) and anisole be

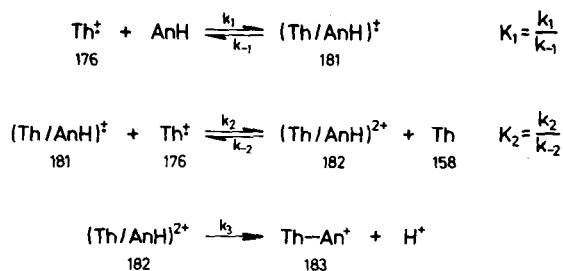

Scheme 43

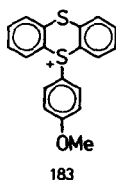

$$-\frac{d[\text{Th}^{\cdot+}]}{dt} = 2k_3K_1K_2 \frac{[\text{Th}^{\cdot+}]^2[\text{AnH}]}{[k_3/k_{-2} + [\text{Th}]}$$

reversible. It was concluded that this step involves the formation of a π complex $(\text{Th}/\text{AnH})^{\cdot+}$, which undergoes electron exchange with (176) to form the dication complex (182) which then irreversibly forms the sulfonium salt (183). When the nucleophile is phenol, the deprotonation of the dication complex takes place more readily.⁸⁹ The general validity of this reaction scheme has been supported by further spectroelectrochemical studies.⁹⁰

The observation that the reaction of (176) with water in acetonitrile is third order in water led to the proposal of a complicated mechanism (Scheme 42 a-d) in which water acts as both a nucleophile and a base.⁸⁴ More recently,⁸⁵ a re-examination of the previous kinetic analysis⁸⁴ has shown that the postulated mechanism (Scheme 42) is inconsistent with the observed rate law. In order for the reaction to be dependent upon $[\text{H}_2\text{O}]$, equilibrium (a) must be displaced to the left. Thus, the mechanism predicts that the steady state concentration of $\text{Th}^{\cdot+}$ greatly exceeds that of $\text{Th}(\text{OH}_2)^{\cdot+}$. Furthermore, $\text{Th}^{\cdot+}$ is expected to be a significantly stronger oxidant than the complexed cation radical. Thus, reaction (c) is expected to be insignificant and it was necessary to include reaction (e) in the mechanism.⁸⁵ Kinetic analysis of this mechanism gives a rate law with a second order water dependence which invalidates the mechanism assignment.⁸⁴ It was concluded that the water reaction in acetonitrile is similar to those of other nucleophiles but there are complications brought about various equilibria of the nucleophile itself.

A kinetic study of the same reaction in dichloromethane-trifluoroacetic acid resulted in a rate law similar to that for the other nucleophiles (Scheme 43).⁸⁵ Thus, it is apparent that

the general mechanism (Scheme 43) holds for most nucleophiles. It should be pointed out that rate laws describing the same overall mechanism can differ with conditions as the rate determining step may change.

XI. THIOPHENES AND BENZODERIVATIVES

1. Oxidation in Methanol.

The anodic oxidation of thiophenes in methanol is a useful synthetic procedure for the preparation of ring opened products mainly (185) and in addition (186) (Scheme 44).⁹¹

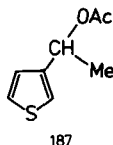
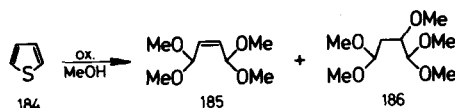

Scheme 44

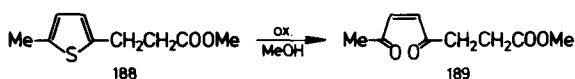

The side chain substituted compound (187) behaved analogously.⁹² These reactions resemble those reported earlier during the oxidation of furan.^{93,94} The diketone (189) was formed under similar conditions.⁹⁵

The oxidation of the benzoderivative (190) gave (191) as the major product and (192) and (193) as minor products (Scheme 45).⁹⁶ Substrates with methyl in the 3 or 2,3-positions behaved similarly.

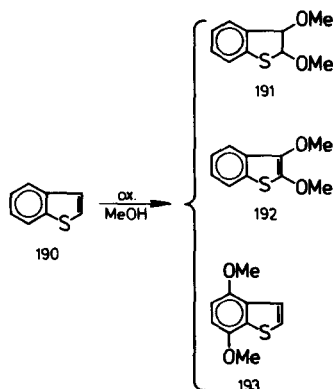

Scheme 45

In the case of (194) where a thiophene ring is joined to a furan ring *via* a methylene group oxidation takes place exclusively in the furan moiety to give (195) (Scheme 46).⁹⁷

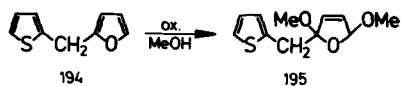

Scheme 46

The symmetrical bis-thiophene (196) gave only side-chain oxidation products (197) and

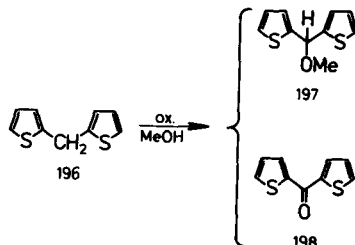

Scheme 47

(198) (Scheme 47).⁹⁷ Compounds in which the thiophene ring is directly linked to a furan ring (199) undergoes substitution to give (200) (Scheme 48).⁹⁸

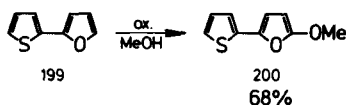

Scheme 48

2. Thioindigo.

Cathodic reduction of 3-thianaphthenone (201) at pH 7.5 and -1.4 V vs. SCE gave 3-hydroxy-2,3-dihydrothianaphthene (202). It was implied from polarographic analysis that under basic conditions the conjugate base (203) is oxidized to thioindigo (204) (Scheme 49).⁹⁹

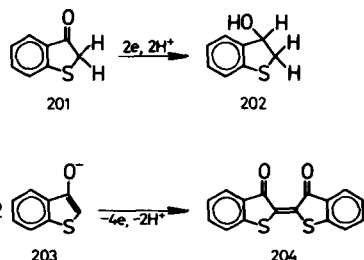

Scheme 49

The reduction of *trans* and *cis* thioindigo was studied by cyclic voltammetry and rotating ring disk electrode voltammetry.¹⁰⁰ The anion radical of the *cis* isomer was observed to rapidly rearrange to the *trans* anion radical. The cyclic voltammograms of both forms in DMF are shown in Figure 18. In order to prepare the *cis* form in situ, it was necessary to irradiate the solution with light filtered through a Corning 3-68 filter. The voltammogram was then recorded during radiation. The oxidation peak prominent on the reverse scan in the case of the *cis* isomer is due to a dimeric reaction product. Dimer forming reactions were observed to be considerably faster during voltammetry of the *cis* isomer.

The kinetics of several reactions of anion radicals of (205) where R is H with CO₂, acrylonitrile and cinnamionitrile were studied by controlled potential reversal coulometry.¹⁰¹ In the presence of benzoic acid the reduction product was found to be (206)

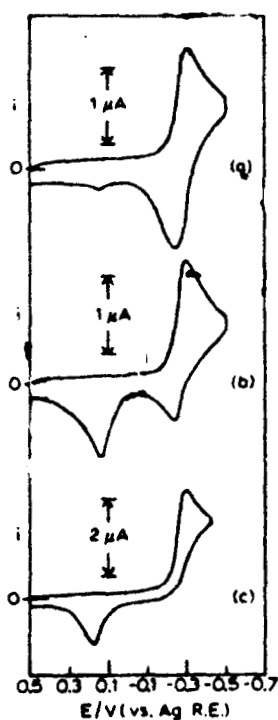
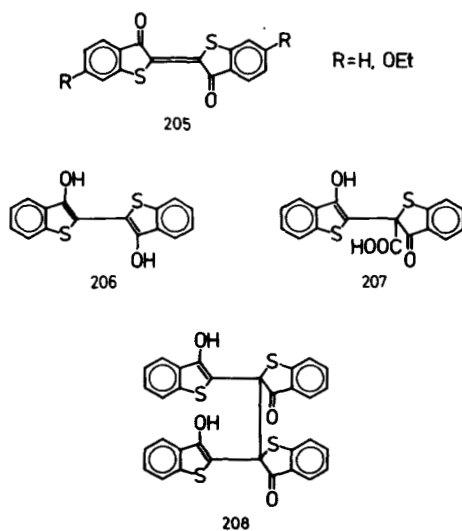

FIGURE 18 Cyclic voltammograms of thioindigo (0.25 mM) in DMF. Voltage sweep rate, 100 mV/s. (a) *Trans*-isomer, (b) *cis*-isomer and (c) *trans*-isomer in the presence of benzoic acid (25 mM). (Reprinted from Ref. 100 by courtesy of Elsevier Sequoia S.A.).

while the presence of CO_2 , (207) was proposed to be the product. The products in the presence of the nitriles were proposed to be the Michael addition adducts. In the absence of other reactants the dimer (208), on the basis of cyclic voltammetry, was proposed to be the product. It was pointed out that more careful product analysis is desirable.



Studies were also carried out on the reduction of (205), where R is EtO, and results consistent with those of the unsubstituted compound were obtained.¹⁰²

3. Dibenzothiophene.

Dibenzothiophene (209), upon anodic oxidation was found to form the sulfonium salt (210), (Scheme 50).¹⁰³ This reaction is analogous to the oxidation of diphenylsulfide

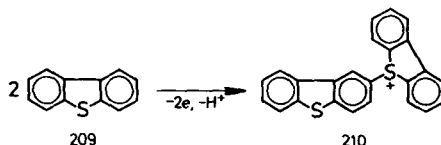

Scheme 50

(XIII.2). The reaction was studied by cyclic and a.c. voltammetry. The heterogeneous rate constant was estimated to be equal to $10^{-2.8}$ cm/s. The follow-up reaction was observed to be rapid and irreversible. Three possible mechanisms were proposed to be consistent with the data and could not be distinguished. However, two of the proposed involve the formation of highly unlikely intermediates, aryl radicals and aryl cations, and need not be considered. The remaining mechanism, a usual anodic substitution, is feasible and highly likely.

XII. THIOLS AND DISULFIDES

1. Introduction

A large amount of work has been published concerning the electrochemistry of thiols and disulfides. We will limit our coverage to papers most concerned with structural and mechanistic aspects of the reactions. For more complete coverage, Refs. 1-4 and 104 are recommended. Both the oxidation and reduction reactions are generally described by Scheme 51 where thiols are reversibly interconverted to disulfides with a near independence of the nature of R.

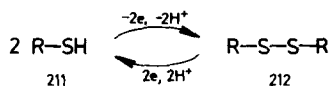

Scheme 51

2. The Thiol-Disulfide Redox System.

The general Scheme 51 can be broken down into the individual steps for the oxidation of thiols (211) to the disulfides (212) as in Scheme 52. The oxidation may involve a direct oxidation of (211) or the conjugate base (213) depending on the reaction conditions.

The processes involved in Scheme 52 have been investigated in detail in one case, where R is phenyl.¹⁰⁵ The oxidation of (213) was observed to take place at about 1 V less positive than the oxidation of (211). An interesting observation from this and other studies is that (212) are not reducible at a platinum electrode in protic solvents but are readily reduced in aprotic solvents such as DMF.¹⁰⁵⁻¹⁰⁷

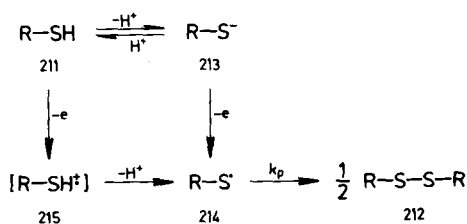

Scheme 52

The reduction of disulfides (212) can likewise be amplified to show the individual steps as in Scheme 53. The initial intermediate, anion radical (216) can undergo cleavage to give

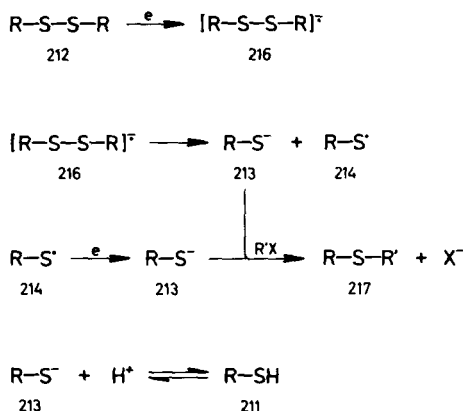

Scheme 53

(213) and (214). The intramolecular cleavage of the anion radical of (218) is a particularly interesting example of this reaction.¹⁰⁷ The existence of (213) could be demonstrate by

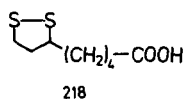

chemical trapping with alkylating agents such as dimethyl sulfate¹⁰⁸ or methyl halides^{62,63} as well as oxygen.¹⁰⁹ In the latter case the product is a sulfinate ion.

Another means of identifying the fragments of the cleavage of anion radicals (222) has been attempted.¹¹⁰ A co-electrolysis of (221) and (219) was observed to result in the formation (226) which was attributed to the reaction of radical (224) with anion radical (220) (Scheme 54).

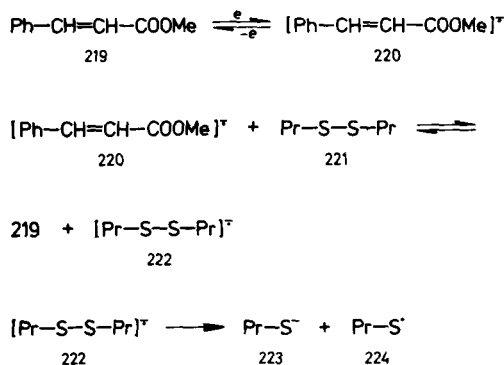

Scheme 54

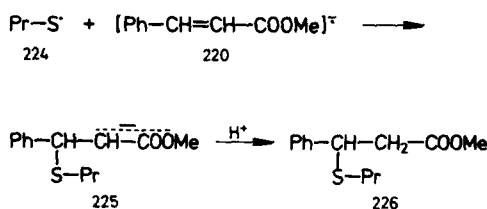
Scheme 54
(continued)

An inventive approach to the elucidation of the details of the cleavage reaction has been presented.¹¹¹ A solution containing both (227) and (229) (Scheme 55) was subjected

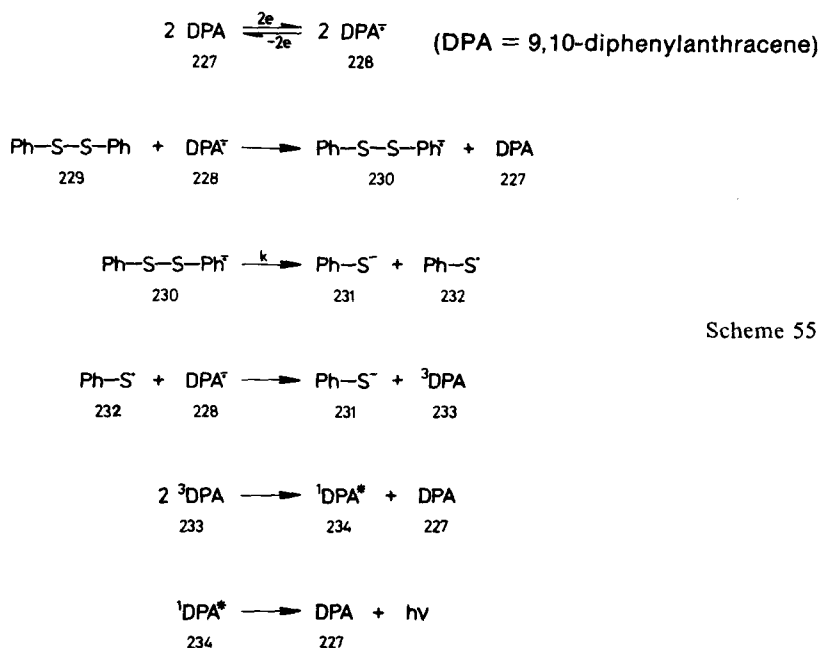

Scheme 55

to polarographic reduction. The results of this experiment are illustrated in Figure 19. At the potential where (229) is reduced, $E_{1/2} = -0.85$ V vs. SCE, no fluorescence emission could be observed. However, near the potential where (227) is reduced electrochemiluminescence was observed as shown by curve 2 in Figure 19. The reactions taking place are summarized in Scheme 55. The electrochemiluminescence is due to the demotion of singlet state (234) formed in the bimolecular energy transfer reaction of triplet (233). This then provides evidence for the electron transfer reaction between (232) and (228). In the potential region where (228) is reduced to the dianion, other reactions apparently take place giving rise to a reduction in the intensity of the emission.

3. The Role of Mercury in the Electrode Processes.

The fact that (212) are reduced on mercury but not on platinum in protic solvents suggests that this is simply a consequence of the higher overvoltage attainable with mercury. However mercury has been found to play a chemical role in both oxidation of thiols and reduction of disulfides.¹¹²⁻¹¹⁷ A number of the reactions involving mercury which have been proposed and in some cases demonstrated are summarized in Scheme 56. The

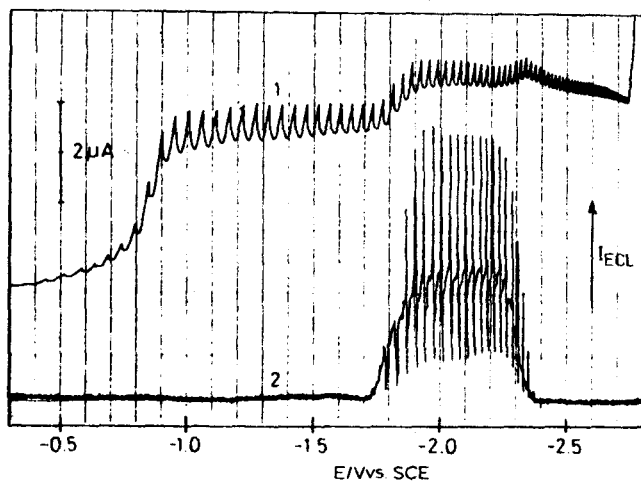
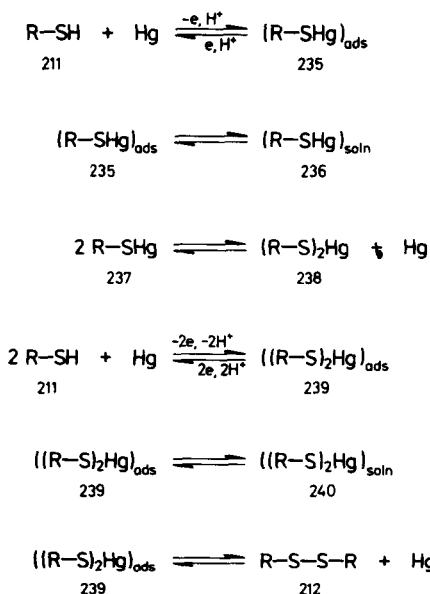

FIGURE 19 Polarogram (1) and luminescence-potential curve (2) of Ph-S-S-Ph/DPA (concentrations 1.0 mM) in DMF at the dropping mercury electrode. (Reprinted from Ref. 111 by courtesy of Elsevier Sequoia S.A.).



Scheme 56

difficulties involved in the demonstration of the role of mercury in the electron transfer reactions have been discussed.¹¹⁶ For the reduction of diphenyldisulfide in DMF and DMSO, the assistance by mercury could neither be established nor refuted. On the other hand the reverse reaction, the oxidation of (238) where R is aryl, could be demonstrated.¹¹⁷

4. Sulfur Containing Amino Acids.

The biologically important interconversion as exemplified by the cysteine (241)-cystine (242) couple has received much attention.^{1,104,118-124} This interconversion is shown in

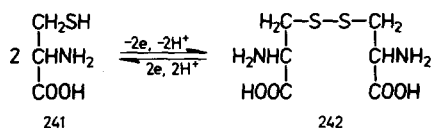

Scheme 57

Scheme 57. Here again, mercury plays an active role which has been demonstrated for both the oxidation and reduction reactions.¹¹⁸⁻¹²⁰ The processes have also been studied on gold electrodes where complications due to adsorption of both substrate and intermediates were encountered.¹²¹⁻¹²² The adsorption was studied in one case by ³⁵S radiometry on platinum electrodes.¹²³ On platinum further complications were observed in that the reaction appeared to be facilitated by the formation of an oxide film or adsorbed oxygen.¹²⁴

5. Reduction of Thiols.

Although the electrode reaction of most importance with thiols is oxidative coupling, cathodic reactions have also been reported.¹²⁵⁻¹²⁸ An interesting dependence of the position of the thiol group was observed in the reduction of (243) (Scheme 58) and (247)

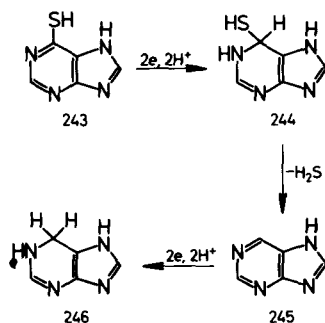

Scheme 58

(Scheme 59).¹²⁵⁻¹²⁷ Compound (243) substituted in the 6-position gives rise to the formation of (245) accompanied by the expulsion of H₂S. Further reduction of (245) results in

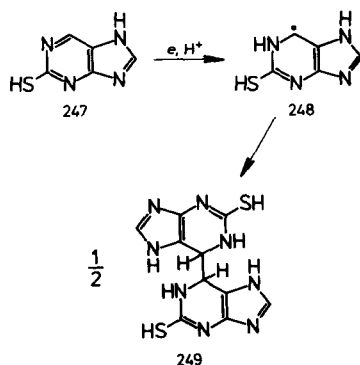

Scheme 59

the dihydro derivative (246). The 2-substituted compound (247) undergoes one electron reduction to the radical (248) which dimerizes to (249). In this case the thiol group remains intact. An example starting with a thiolate (250) is shown in Scheme 60 which again results in the expulsion of the sulfur containing fragment.¹²⁸

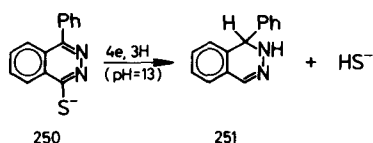

Scheme 60

6. Oxidation of Disulfides.

The oxidation of (252) has been reported to give (253) as described earlier (XII.3) as well as (254) in proportions depending upon the amount of charge passed.¹¹⁷ This indicates that disulfide (253) can be oxidized to the thiosulfonate (254) which was also demonstrated directly (Scheme 61) when the reactions were carried out in DMF

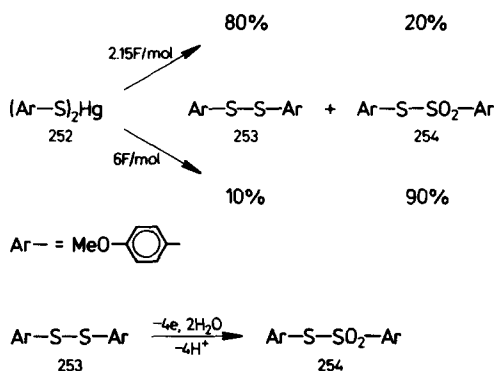

Scheme 61

containing LiClO_4 . The oxidation of (229) on the other hand in acetonitrile containing NaClO_4 was proposed to give the cation radical (255) upon anodic oxidation and the ultimate formation of (256) and ClO_2 (Scheme 62). The latter implicates the supporting

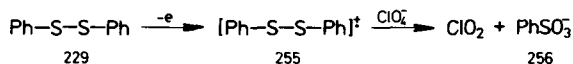

Scheme 62

electrolyte anion in the oxidation process.¹²⁹ Co-electrolysis of (212) and an alkene resulted in potentially useful intermediates (259) in reasonably high yield (Scheme 63).¹³⁰

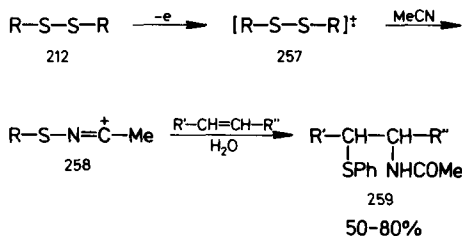

Scheme 63

XIII. SULFIDES

1. Introduction.

Some of the compounds which formally belong in this section have been dealt with already; *i.e.* tetrathioethylenes, thianthrenes, thioxanthene, and orthothiocarboxylates.

2. Oxidation in Aprotic Solvents. The Formation of Cation Radicals and Sulfonium Salts.

A large series of sulfur containing compounds (260)–(281) were studied by rotating platinum electrode voltammetry or cyclic voltammetry.^{131,132} Electrode potentials were correlated with molecular orbital parameters and charge transfer maxima and good cor-

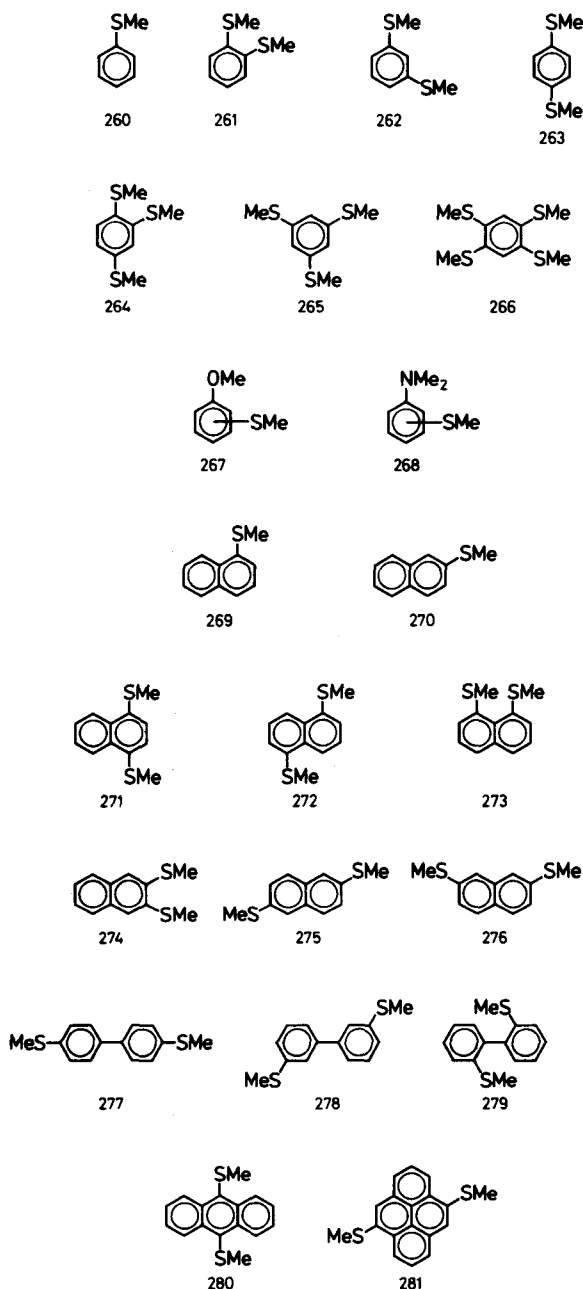

respondence was found. Electrochemiluminescence was observed in some cases when the solutions in DMF were subjected to electrolysis with an a.c. voltage of 3–10 V amplitude.

The phenomenon is due to the reaction of anion radicals with cation radicals generated in different phases of the potential variation.¹³²

The bis-sulfide (282) was prepared as a model tetraalkylcyclobutadiene in order to test for the energy levels of the highest occupied and lowest unoccupied molecular or-

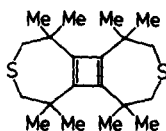

282

bitals and to compare with theoretical predictions. The data supported theoretical predictions that (282) should be more easily oxidized and reduced than some simple reference compounds. It was concluded that the sulfur atoms were not involved in either oxidation or reduction of (282).¹³³

An interesting study was carried out on the cyclic bis-sulfides (283) to test for transannular interaction between the heteroatoms in the oxidation process.¹³⁴ The data

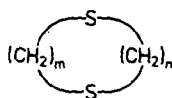

283

reproduced in Table IV show that the oxidation potentials are in most cases significantly lower for the bis-sulfides than corresponding mono-sulfides which suggest that transannular interactions indeed do give rise to the facile reversible oxidation processes. Rotating disk electrode measurements showed that in all but one case the processes consist of two electron oxidations to the corresponding dication. The exception was 1,4-dithiacyclohexane (283- $m = 2, n = 2$) in which case the wave was found to correspond to a single electron process probably giving rise to the formation of a dimeric dication.

A good example of the use of modern electroanalytical techniques³⁶ is found in the studies recently reported on the oxidation of (284).¹³⁵ The overall reactions demonstrated are summarized in Scheme 64. The cyclic voltammograms (Figure 20) show the unusual

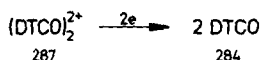
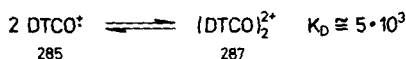
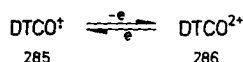
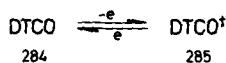
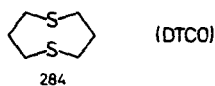

Scheme 64

TABLE IV
Anodic Oxidation of Mono- and Dithioethers.¹³⁴

compd	E_p^a	$nD^{2/3} \times 10^{4b}$
1,3-dithietane	1.13	10.8
1,4-dithiacyclohexane	1.25	5.4
1,5-dithiacyclooctane (1,5-DTCO)	0.343	13.6
1,5-dithiacyclononane (1,5-DTCN)	0.424	12.7
1,6-dithiacyclodecane (1,6-DTCD)	0.424	11.2
1,3-dithiacyclohexane	1.14	12.3
1,4-dithiacycloheptane (1,4-DTCH)	0.75	11.9
1,4-dithiacyclooctane (1,4-DTCO)	0.81	11.8
7,8-benzo-1,5-dithiacyclononane	0.48	11.2
3,4,8,9-dibenzo-1,6-dithiacyclodecane	0.62	9.8
2,5-dithiahexane	0.97	10.0
2,6-dithiaheptane	0.66	12.3
2,7-dithiaoctane	0.67	
thiolane (tetramethylene sulfide)	1.13	11.1
thiane (pentamethylene sulfide)	1.32	
4-oxathiane	1.31	15.5
1-thiacyclooctan-5-ol	0.72	12.4

^a Peak potentials of first oxidation peak determined at a Pt-electrode in acetonitrile. Potentials are given vs. Ag/0.1 M AgNO₃ in AN.

^b Estimated from rotating disk electrode measurements.

effect that decreasing the voltage sweep rate gives an apparently more reversible voltammogram. The latter is due to the reversible dissociation of (287) to (285). Apparently, at the highest sweep rate, 10 V/s dissociation appears slow while at the other extreme 0.01 V/s dissociation is sufficiently fast on this time scale to give rise to an essentially reversible cyclic voltammogram.

The effect of neighboring group participation in oxidation processes was delineated during voltammetric studies on (288) and (289).¹³⁶ The oxidation potentials of the *exo*

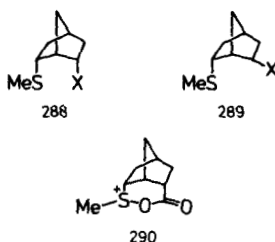

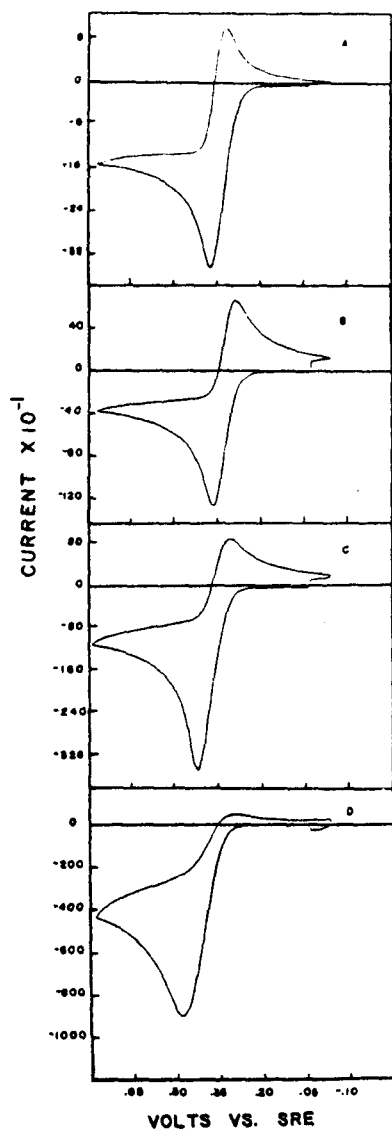

FIGURE 20 The effect of the voltage sweep rate on voltammograms of DTCO (284) in acetonitrile. (A) 10 mV/s, (B) 100 mV/s, (C) 1 V/s and (D) 10 V/s. (Reprinted from Ref. 135 by courtesy of The American Chemical Society).

isomer (289) were observed to be essentially independent of the nature of X (Table V) while those of the *endo* isomers were strongly dependent upon the latter. The most effective X in the participation was observed to be carboxylate which was found to lower the potential for oxidation of (288) 0.63 V in comparison to the corresponding (289). The carboxyl group was observed to be much less effective bringing about only an 0.08 V decrease for the *endo* isomer oxidation potential. The structure proposed for the two electron oxidation product for (288-X = COO⁻) is (290).

The oxidation of dimethylsulfide (291) in acetonitrile containing sodium perchlorate and water (1%) gave exclusively dimethylsulfone.¹³⁷ In dry acetonitrile the ultimate products were observed to be methane sulfonate and CO. The initial steps were proposed

TABLE V
Anodic Oxidation of Norbornyl Derivatives Using Cyclic Voltammetry.¹³⁶

X	E_p^{OX} (V vs. Ag/Ag ⁺)	
	(288)	(289)
COOH	1.20	1.28
COOMe	1.21	1.29
CH ₂ OH	0.56	1.20
NHCOOEt	0.98	1.20
COO ⁻	0.65	1.28

to consist of deprotonation of (292) and further oxidation to give (293) which can react with substrate to give the sulfonium salt (294) (Scheme 65). The proposed mechanism for

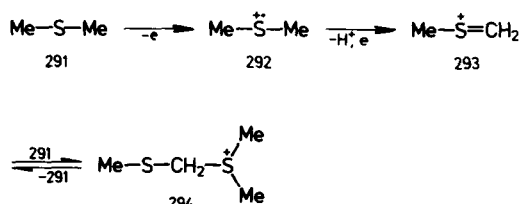

Scheme 65

the formation of the observed products involves a chemical oxidation of further intermediates by Cl₂O₇ believed to be present in equilibrium with perchloric acid generated by reactions with protons liberated in the primary process.

Oxidation of alkylphenylsulfides (295) in acetonitrile containing lithium perchlorate gave reasonably good yields of sulfonium salts (299) according to the generalized Scheme 66.¹³⁸

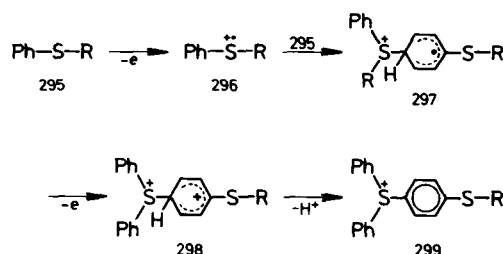

Scheme 66

	<u>299</u>
R = Methyl	60 %
3-Butenyl	67 %
Cyclohexyl	57 %
Phenyl	71 %

The oxidation of diphenylsulfide (300) is more complicated because the sulfonium salt (301) is oxidized giving ultimately (303) as indicated in Scheme 67.¹³⁹ The effect of water

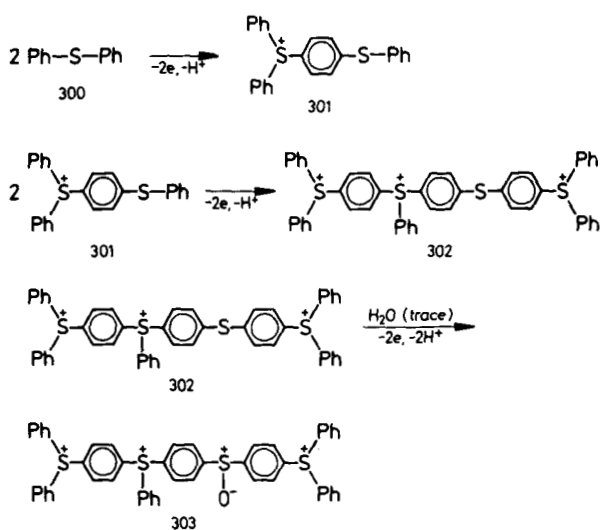

Scheme 67

in acetonitrile on the product distribution was studied.¹⁴⁰ In dry acetonitrile the sulfonium salt (301) was almost the exclusive product while in the presence of water (10%) the ratio of products (301)/(304) was observed to be about 2/1 (Scheme 68).

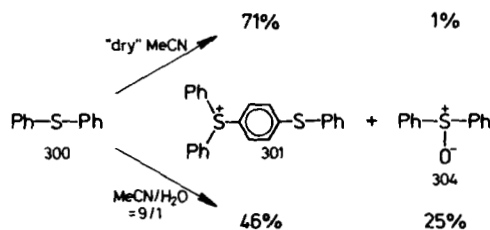

Scheme 68

The effect of the nature R on the oxidation products of (295) in acetonitrile containing water (0.5%) has been studied.¹⁴¹ The results (Scheme 69) show that the partitioning

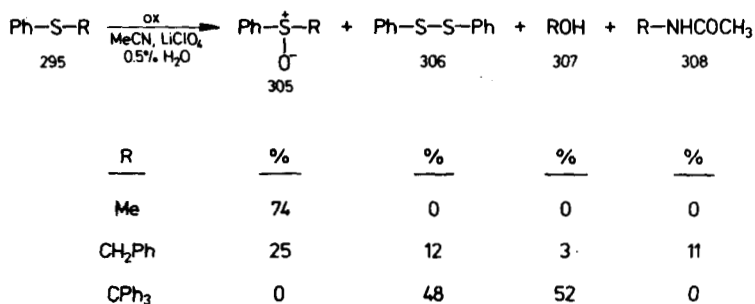

Scheme 69

between hydroxylation and cleavage of the cation radical of (295) is strongly dependent upon the stability of the cation R⁺ generated during cleavage.

3. Oxidation in Protic Solvents. The Formation of Sulfoxides and Sulfones.

Under these conditions, oxidation of (309) was observed to take place stepwise to (310)¹⁴² or to (311)¹⁴³ depending upon the extent of oxidation (Scheme 70).

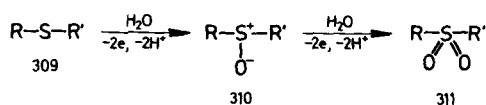

Scheme 70

More recent detailed studies have been carried out in aqueous acetic acid on the oxidation of diphenylsulfide which proceeds in near quantitative yield.^{144,145} A number of techniques including cyclic voltammetry, coulometry, the recording of polarization curves and logarithmic current-concentration analysis were applied. The three mechanistic proposals had the common features of substrate adsorption on either the platinum electrode or a platinum oxide film.

Oxidation of (312) in methanol containing methoxide ion gave the products shown in Scheme 71. Similar trends in the products were obtained from electrolysis and thermal decomposition of a precursor to (313), *tert*-butylphenylthioperacetate.¹⁴⁶

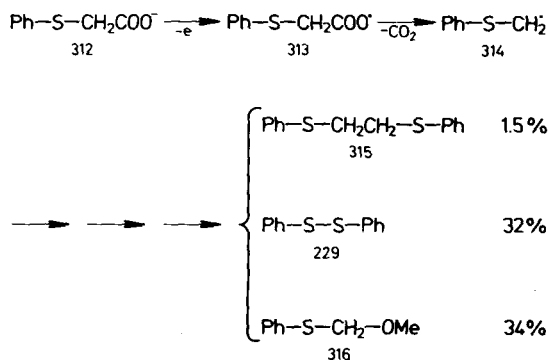

Scheme 71

The cation radical (317) has been used as an electrocatalytic mediator in the oxidation of alcohols (Scheme 72).¹⁴⁷ Oxidation of (260) in benzonitrile containing the alcohol and

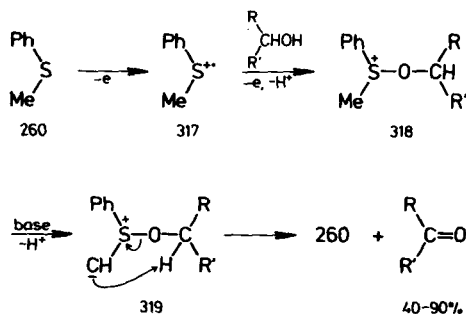

Scheme 72

2,6-lutidine gave the ketones in moderate to good yields in spite of the fact that the process is apparently very inefficient in terms of the charge consumed.

4. Thioacetals.

The oxidation of (320) to (212) in high yields was reported independently by two groups.^{148,149} Different mechanisms (Scheme 73¹⁴⁸ and 74¹⁴⁹) were proposed to account for the observed products. Very strong support for the validity of Scheme 73 was obtained in a studies of cyclic (330).¹⁵⁰ The most convincing evidence for the participation of a cyclic

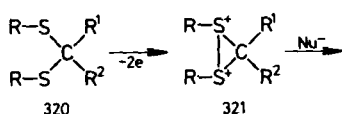

Scheme 73

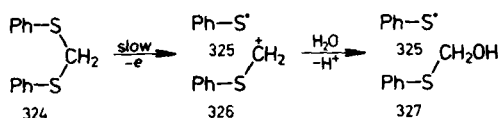
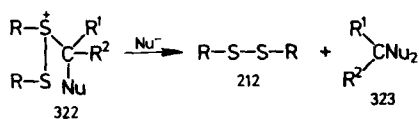

Scheme 74

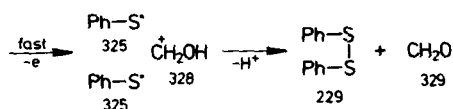

intermediate such as (321) was the observation that 2-phenyl-1,3-dithiolan (333) gave only 5% of the carbonyl compound while 2-phenyl-1,3-dithian gave high yields of benzaldehyde

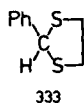

333

(Scheme 75). This suggests that the intermediate in the first case having a four membered ring fused to the three membered ring is highly strained and other reactions are favored.

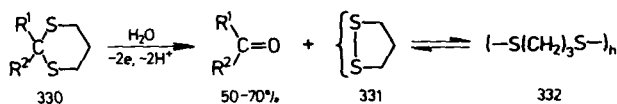

Scheme 75

In the second case involving fused five and three membered rings in the intermediate less strain is involved and the reaction is favorable. The effect of structure on the yields is not an expected consequence of the mechanism depicted in Scheme 74. These reactions are useful in the removing of dithian protecting groups for carbonyls. Other series of compounds including (334) were investigated.¹⁵¹⁻¹⁵³

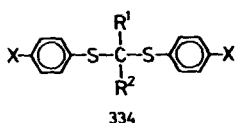

334

X = H, Me and Cl, Me

5. Miscellaneous Oxidations of Sulfides.

Compounds (335) (Scheme 76)¹⁵⁴ and (337) (Scheme 77)¹⁵⁵ when subjected to anodic oxidation under aqueous conditions gave the corresponding carbonyl compounds (336)

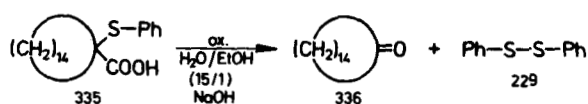

Scheme 76

and (338) together with diphenyldisulfide (229) in high yields. In the presence of methanol, the acetal (339) and (340) are formed during oxidation of (337).¹⁵⁵

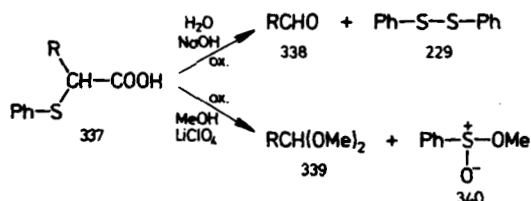

Scheme 77

A convenient synthesis of compounds containing the structural features of (342) or (343) has been found in the anodic oxidation of compounds (341).¹⁵⁶ Excellent yields were reported (Scheme 78).

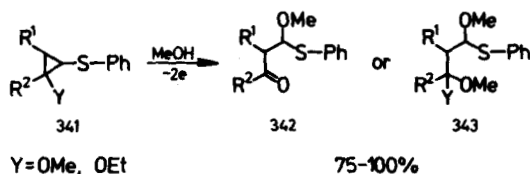

Scheme 78

The oxidation of vinylsulfides (344) provides a convenient synthesis of α -alkylthioaldehydes (345) (Scheme 79).¹⁵⁷ The reaction was carried out at controlled potential in aqueous acetonitrile.

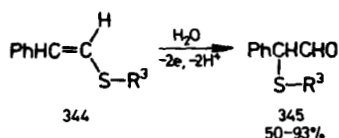

Scheme 79

6. Reduction of Sulfides.

Sulfides (295) are reduced in DMF to (347) and (350) (Scheme 80).¹⁵⁸ Three reaction pathways were discussed and it was proposed that most of the anion radicals (346) undergo reaction pathways (a), (b) or (c). Compounds (351) to (353) were observed to

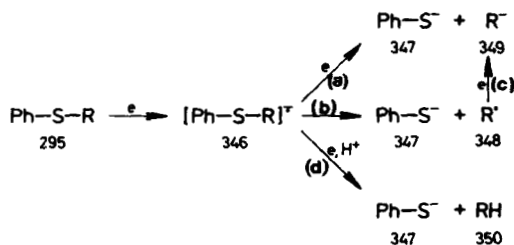

Scheme 80

undergo one electron processes in DMF which changed to two electron steps when phenol was added.

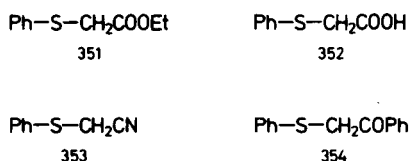

The reduction of (354) has been studied in aprotic solvents.^{159,160} Although the electrochemical reaction involves a two electron reduction, deactivation of substrate in the acid-base reaction with (355) results in an apparent n value of 1 (Scheme 81). The same

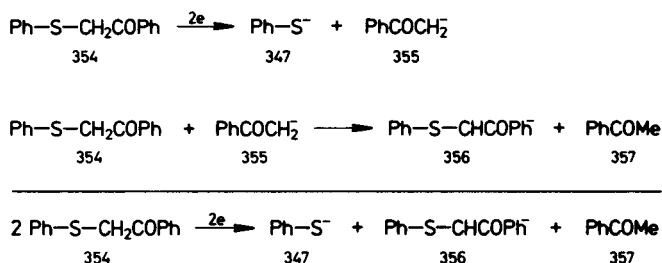

Scheme 81

general behavior was observed during the reduction of (358-R = aryl) but no cleavage was observed when R was alkyl, in which case the carbonyl function was reduced to the alcohol (Scheme 82).¹⁶¹

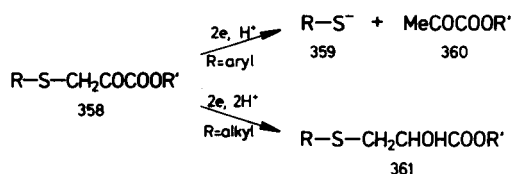

Scheme 82

A gallant attempt to verify stereospecific reductive cleavage of optically active ethyl 2-phenylmercaptopropionate (362) failed to give anticipated results in that the optical purity of the product (363) was only 2–4% (Scheme 83).¹⁶²

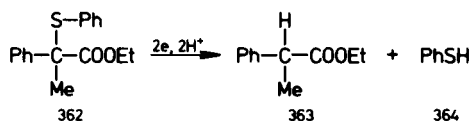

Scheme 83

The electron itself has been shown to be a reducing agent during the electrolysis of (365) in DMF (Scheme 84).¹⁶³ Elimination of water and phenylthiolate resulted in the

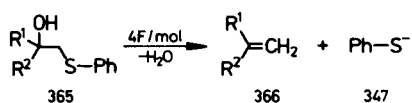

Scheme 84

formation of (366) in good yield. Two electron reduction of (367) resulted in cleavage to the bis-carboxylate (368).¹⁶⁴ Only partial recovery of substrate could be achieved upon oxidation due to competing reactions (Scheme 85).

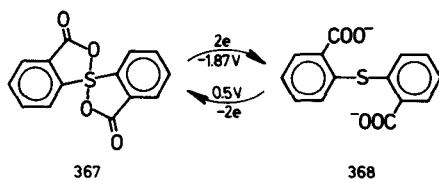

Scheme 85

An interesting structural effect on the cleavage of thiocyanates (369) and (374) has been reported (Scheme 86).¹⁶⁵ The intermediate anion radical (370) was found to decompose in a first order reaction with a rate constant of 0.23 s^{-1} in acetonitrile at 22.5°C to give (373).

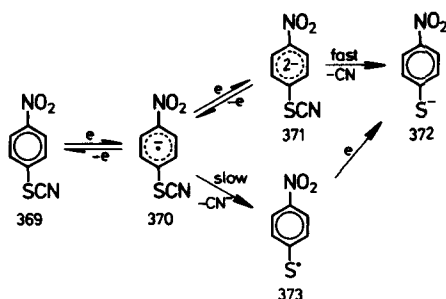

Scheme 86

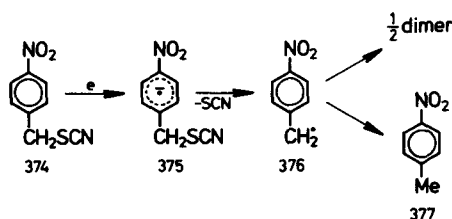

Two reduction peaks were observed during cyclic voltammetric experiments on *p*-nitrobenzyl thiocyanate (374) in acetonitrile. The anion radical was found to decompose rapidly to an electroactive species which was reduced at the second peak. Exhaustive electrolysis of (374) resulted in the formation of both the dimer, 4,4'-dinitrobenzyl, and (377). The rate constant for the conversion of (375) to (376) was estimated to be about $2 \times 10^4 \text{ s}^{-1}$. The reason for the differences in bond points of cleavage is probably connected with the relative stabilities of the radicals generated.

The participation of neighboring sulfur in the reduction of a series of thiacyclonones was investigated for compounds (378) to (385).¹⁶⁶ Compounds containing sulfur were

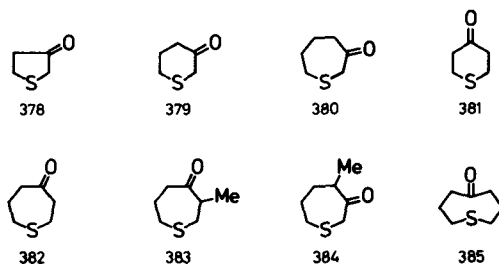

observed to be more easily reduced than the parent cyclic ketones. The magnitude of the effect was observed to be dependent upon the ring size and position of the sulfur atom.

Reduction of (386) gave rise to a variety of products of which (387) and (388) were most prominent.¹⁶⁷ A detailed product analysis also showed the presence of the other minor products shown in Scheme 87.

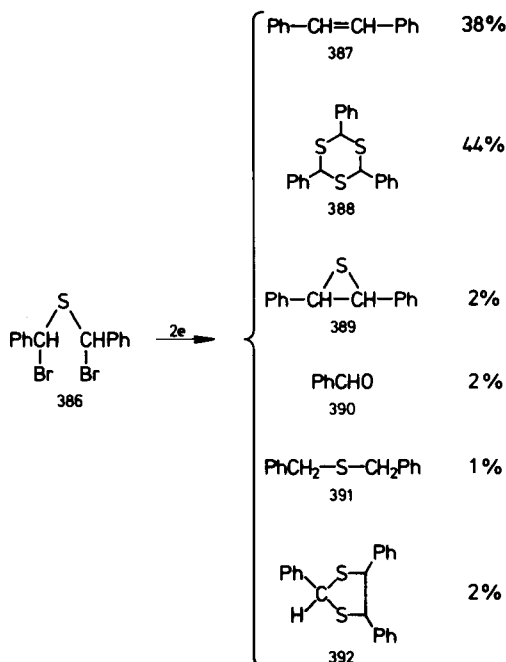

Scheme 87

XIV. SULFONIUM SALTS

The reduction of sulfonium salts produces the radical (394) as the primary intermediate (Scheme 88). In most cases (394) is expected to be unstable with respect to decomposition to the sulfide (395) and radical (396). Thus the chemistry observed is that of the radical

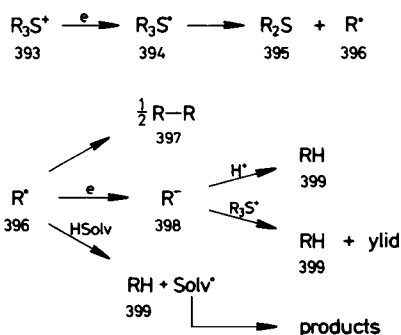

Scheme 88

(396). Possible reaction pathways are dimerization to (397), reduction either at the electrode or in solution to the carbanion (398) or hydrogen atom abstraction from the medium to give the reduced product (399). The presence of (393) gives rise to a special reaction of the carbanion (398) with the formation of (399) and an ylid.¹⁶⁸⁻¹⁷⁰

The reactions illustrated in Scheme 88 assume that the electrode is acting only as a

source of electrons and does not chemically interact with the intermediates. This situation is apparently realized when platinum or aluminum is used as the electrode.¹⁶⁸⁻¹⁷⁰ When the electrode is mercury a more intimate interaction is involved (Scheme 89).¹⁷¹⁻¹⁷² The

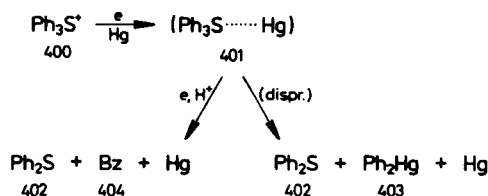

Scheme 89

reaction is formulated as an atom and electron transfer giving the complex (401) which may either undergo electron and proton transfers to give (402) and (404) or disproportionate giving (402), diphenylmercury (403) and mercury.

Cyanomethyl dimethylsulfonium salt (405) undergoes apparent one electron reduction to give (408) in high yield (Scheme 90).¹⁷³ This is another case where the primary process

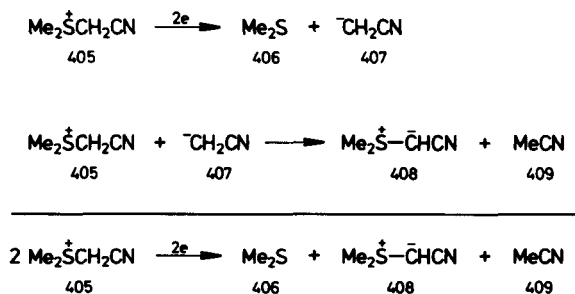

Scheme 90

involves two electron reduction but further reaction consumes one mole of substrate. A similar reaction has been observed during reduction of dimethyl-9-fluorenylsulfonium ion to give the stable ylid (410).¹⁷⁴ This method has been employed to generate ylids in

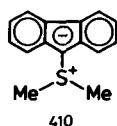

preparative studies.¹⁷⁵⁻¹⁷⁶ The reduction of (411) in the presence of carbonyl compounds gave potentially useful epoxides (Scheme 91) in moderate yields.

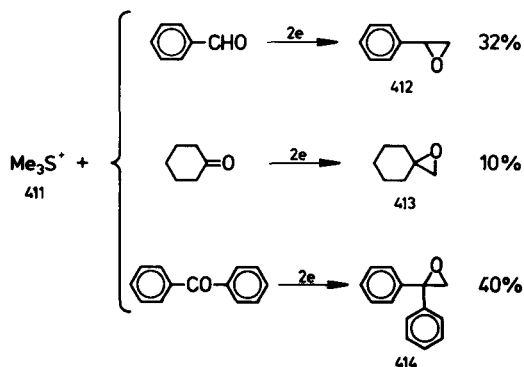

Scheme 91

The cleavage reactions already discussed for the reduction of sulfonium salts have also been employed in synthetic work. Sulfonium ion (415) was observed to undergo two electron reduction in the presence of acrylonitrile (416) to give 3-phenylbutyronitrile (417) (Scheme 92).¹⁷⁷ The yield in this case was 29%.

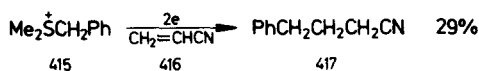

Scheme 92

XV. THIOKETONES

1. Reduction of Thioketones.

Only simple thioketones will be treated here. Thioesters and related compounds have been discussed in sections VIII and IX. Polarography in buffer solutions (32 different) showed that (418) is reduced in a two electron-two proton step to give (419) (Scheme 93).¹⁷⁸ The same conclusion was arrived at by polarographic studies in water 2-propanol

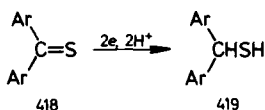

Scheme 93

(40%).¹⁷⁹ Further details of this overall scheme was reported from results obtained in a polarographic study of the reduction of (420) and (421).¹⁸⁰ In acid solution it was proposed that the reaction involves a preliminary protonation equilibrium followed by

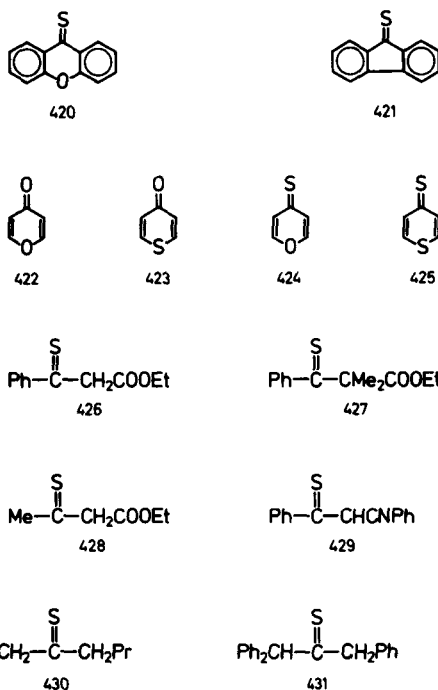

two consecutive one electron transfers. However, at intermediate and higher pH, direct reduction of the thione was postulated to take place before protonation. In strongly alkaline solution dimerization of the intermediate radicals was believed to be the general reaction pathway but the radical derived from (420) reduces further to the parent hydrocarbon. Plots of the half-wave potentials measured in acetonitrile were found to correlate linearly with the energy of the longest wavelength absorption band ($n \rightarrow \pi^*$). A similar linear relationship was found between half-wave potentials and spectroscopic parameters.¹⁸¹ Heterogeneous charge transfer kinetics were studied by an a.c. method during the reduction of three different thiobenzophenones. Rate constants ranging from 0.1 to 0.2 cm/s in acetonitrile at 25°C were reported.

Polarography was used to show that the ease of reduction increases in the order (422) > (423) > (424) > (425) in aqueous buffer at pH 7.¹⁸² The half-wave potentials and the energies of the lowest vacant π orbitals showed no apparent correlation while an approximate linear dependence was found between the energy of the first intense absorption band and the half-wave potentials.

Compounds (426) and (428)–(431) in contrast to (427), have enolizable hydrogens which give rise polarograms in which the reduction of both the enthiol and thione are evident.¹⁸³ Analysis of the polarograms indicated that the percent of thione present varied between 33% (430) and 0% (431). It was further demonstrated that enthiol-thione equilibrium was strongly affected by the nature of the supporting electrolyte cation.

2. Oxidation of Thioketones.

The oxidation of (432) in aqueous solution at platinum electrodes was observed to give (433) and SO₂ in a six electron process (Scheme 94).¹⁸⁴

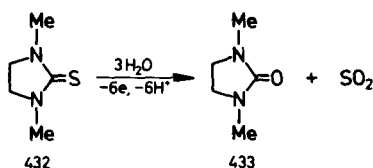

Scheme 94

XVI. SULFOXIDES

1. Reduction of Sulfoxides.

Sulfoxides (434) are reduced in the presence of protons to the corresponding sulfide (435) (Scheme 95).^{185–187} Surprisingly, no polarographic waves could be observed during

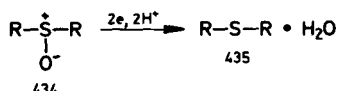

Scheme 95

attempted reduction of the cyclic compounds (436) and (437).¹⁸⁶ The presence of a carbonyl group in the β -position has been observed to bring about a dramatic change in the reaction pathway (Scheme 96 and 97).^{188–190} The initial cathodic cleavage of (441) to (442) is followed by reaction with proton donors or if the reaction is carried out in DMF a

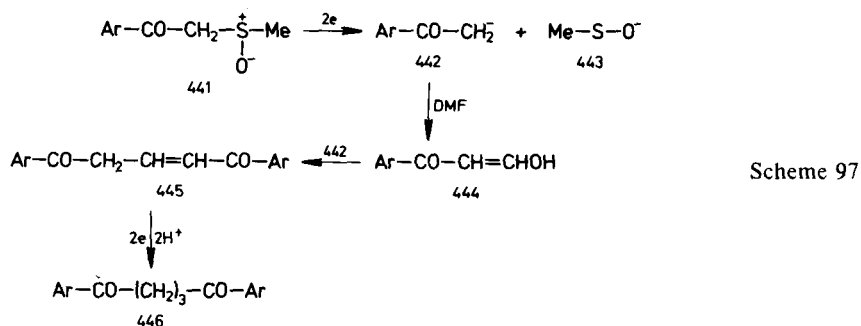
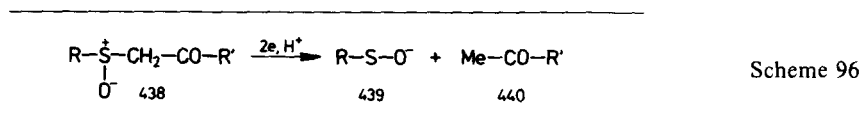
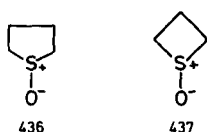

condensation with solvent to give (444) which in turn reacts with carbanion (442) to produce the addition product (445) which is electroactive and is reduced to the 1,5-diketone (446).¹⁹⁰

The cathodic reduction of 1,2-diphenylthiiren monoxide (447) was found to afford products arising from cleavage of the carbon sulfur bonds (Scheme 98).¹⁹¹ The authors

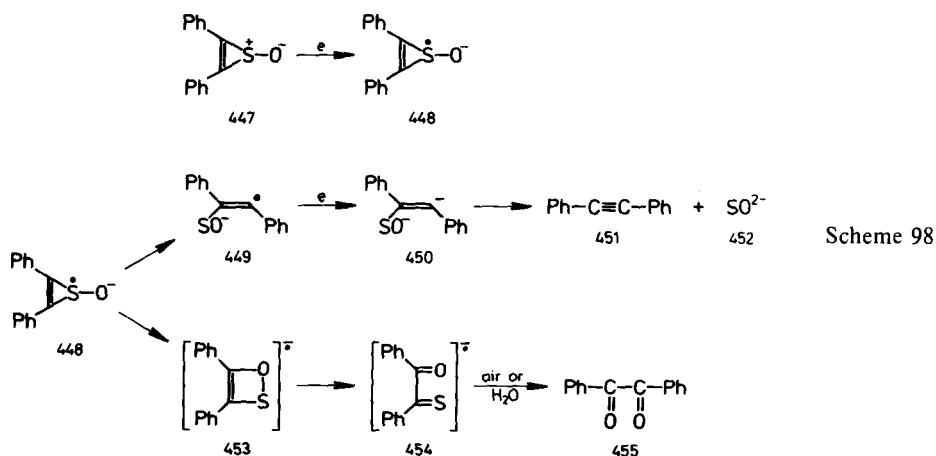

suggested the reaction sequences shown in Scheme 98 to account for the formation of the products. While the reactions leading to (455) appear to be a reasonable formulation, those leading to (451) with the ejection of SO_3^{2-} (452) from the dianion (450) would appear to be somewhat less likely.

2. Oxidation of Sulfoxides.

Little has been reported on this class of reactions.^{74,192-193} The oxidation of (456) in acetonitrile was observed to give the corresponding sulfone (459) in yields of about

50%.¹⁹³ The further observation that when the reaction was carried out in the presence of benzene the formation of the triphenylsulfonium ion (461) without changing the yield of (459) was the basis for the proposal of the reactions in Scheme 99. The key step in this

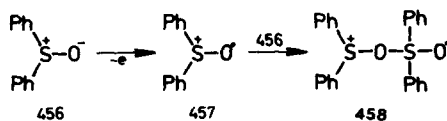

Scheme 99

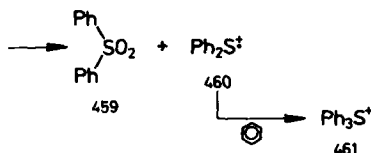

mechanism is the reaction of cation radical (457) with substrate (456) to give unstable cation radical (458) which can undergo rearrangement and decomposition to (459) and (461).

XVII. SULFONES

1. Anion Radical Formation and Mechanisms of Further Reactions.

Diaryl sulfones (462) are rather difficultly reduced, for example the diphenyl derivative is reduced at -2.09 V vs. SCE.¹⁹⁴ The first step has been demonstrated to give the anion radical in a number of cases such as (462)-(475).¹⁹⁴⁻¹⁹⁶ The anion radicals (476) are

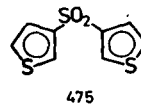
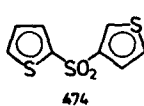
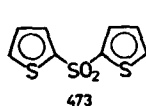
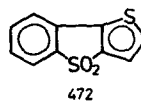
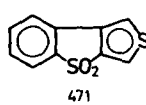
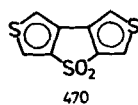
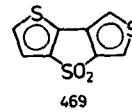
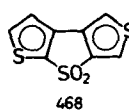
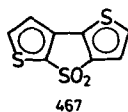
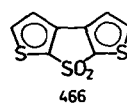
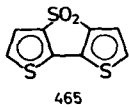
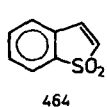
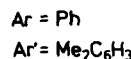
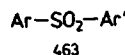
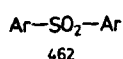

generally reactive and decompose to generate the aryl radical and the aryl sulfinate ion (477) (Scheme 100). The radical is either reduced by electron transfer or undergoes

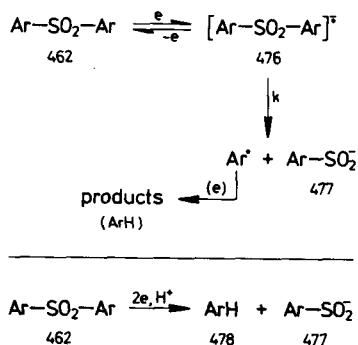

Scheme 100

hydrogen atom abstraction in either case generating (478). Thus, the overall reaction is a two electron one proton reduction.

A great deal of effort has gone into the demonstration of the intervention of aryl radicals in these reactions. A particularly pertinent case is studies conducted on the reduction of (479) (Scheme 101).¹⁹⁷ The proposed reactions of radical (481) to generate

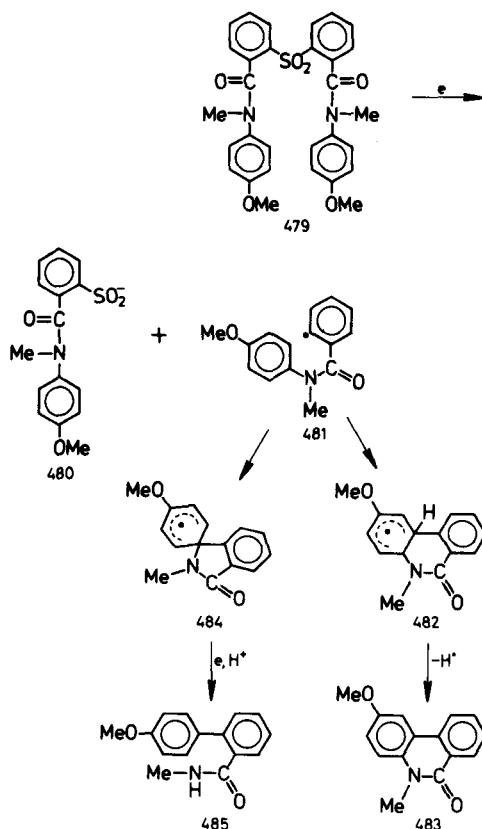

Scheme 101

(483) and (485) were compared to those of (481), generated by halide cleavage from the corresponding aryl halide anion radical. The comparison is shown in Table VI. Although

TABLE VI
Relative Yields of Products after Reduction in DMF at a Hg Cathode.¹⁹⁷

Compound	Solvent	V (vs. SCE)	Relative Yields (%)		
			(481-H) ^a	(485)	(483)
(479)	DMF	-2.0	22	50	28
(481-Br) ^b	DMF	-1.9	33	23	44
(481-Cl) ^c	DMF	-1.6	47	25	28
(479)	H ₂ O	-1.9	26	63	11

^a N-Methyl-N-(4-methoxyphenyl)benzamide.

^b 2-Bromo-N-methyl-N-(4-methoxyphenyl)benzamide.

^c 2-Chloro-N-methyl-N-(4-methoxyphenyl)benzamide.

the comparison is not exact, the correspondence appears to be good enough to support the intermediacy of (481) during the cathodic reduction of (479).

Another view on the reaction mechanism of the decomposition of diaryl sulfones is outlined in Scheme 102.¹⁹⁴ This proposal, based upon cyclic voltammetry and double

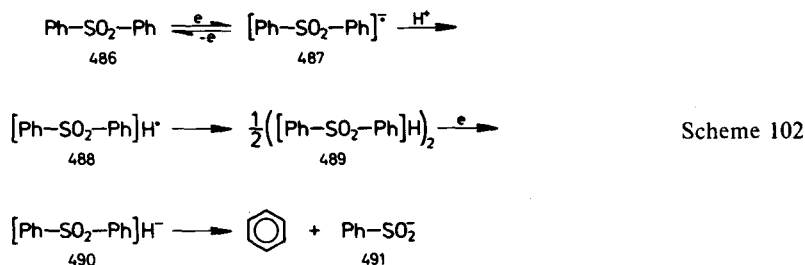

potential step chronoamperometry, involves protonation of the anion radical (487) to give the undefined adduct (488) and subsequent rapid dimerization to (489) and finally further reduction to (490) which cleaves to benzene and benzene sulfinate ion (491).

2. Product Distribution from Reductions of Diaryl and Aryl Alkyl Sulfones.

A very thorough investigation of the cathodic cleavage of unsymmetrical diaryl sulfones (492) was carried out to establish the factors determining which of the two sulfur-carbon bonds are cleaved (Scheme 103).¹⁹⁸⁻²⁰⁰ Product isolation studies were carried out under a very wide variety of conditions where supporting electrolyte cation, electrode material, substrate concentration, current density, and substitution patterns were varied. Structural

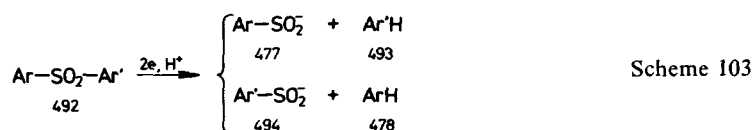

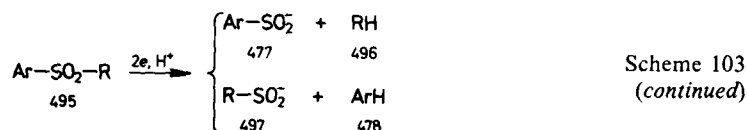

effects were found to be of most importance. In the absence of unfavorable steric interactions, *i.e.* when substituents were in the 4-position, the cleavage of the bond giving rise to the most stable aryl radical was found to be favored. When the substituent was in the 2-position, apparent unfavorable steric interaction brought about an increase in the amount of the less stable aryl radical. The only other variable influencing the reaction was found to be the electrode material, variations of which significantly affected the current yield.

An early report of the reduction pathway of alkylaryl sulfones (495) (Scheme 103) led to the conclusion that aryl radicals were produced.²⁰¹ Only compounds containing aryl groups with electron withdrawing substituents were included in the study. Conflicting results were reported for the reduction of (495) in which only alkyl cleavage was observed.²⁰² More recently, only cleavage of naphthyl was observed when R was methyl in (495).²⁰³ However when Ar was naphthyl and R was benzyl, only benzyl cleavage was observed.²⁰³⁻²⁰⁴ Cyclic arylalkyl sulfones (498) were found to undergo exclusive aryl-sulfur cleavage (Scheme 104). The products were characterized by converting the resulting

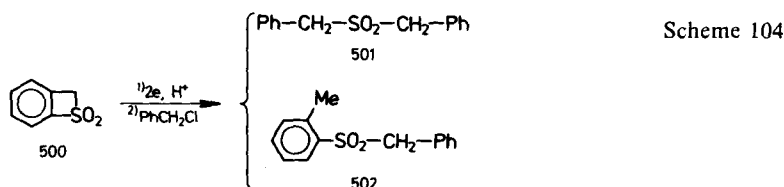
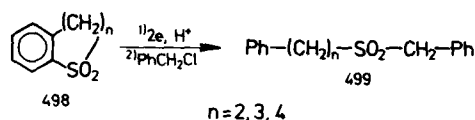

sulfinate ions to benzyl sulfones (499). In the special case, $n = 1$, (500) a mixture of products (501) and (502) were obtained indicating the cleavage of the alkyl-sulfur bond took place as well.²⁰⁵⁻²⁰⁶ On the basis of available data it is difficult to predict which bonds of (495) would be cleaved upon reduction.

3. Di- and Trisulfones.

The difunctional (503) was reduced both cathodically and indirectly with anthracene anion radical as a mediator in DMF.²⁰⁷ Higher selectivity was reported for the indirect method with preferential cleavage as indicated in the structure. Compounds bearing three sulfone groups (504)-(505) have been studied as well.²⁰⁸

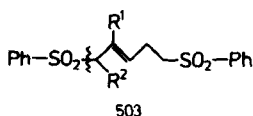

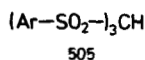
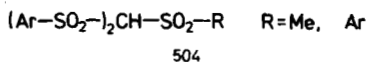

4. Sulfones Containing Other Functional Groups.

Reduction of (506) was observed to produce the sulfinate (491) and the nitrile (507) in moderate yield (Scheme 105).²⁰⁹ It was concluded that the reaction involves a two electron

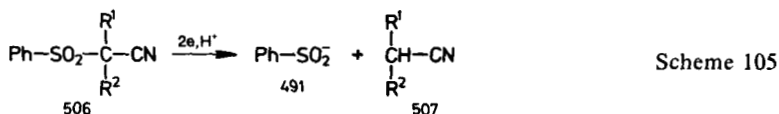

one proton reduction as shown. More recently, the mechanism has been proposed to involve an apparent one electron reduction because of protolytic reactions deactivating starting material.²¹⁰

Electrolytic reduction of (508) in DMF containing acetic acid was found to give (491), (509)–(511) (Scheme 106).²¹¹ More complicated reaction mixtures were obtained in the

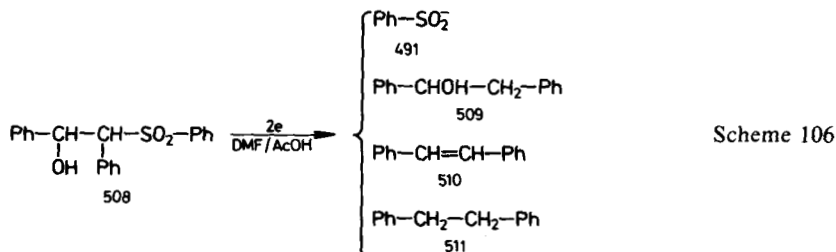

absence of acetic acid and this was attributed to reaction of the substrate with electrolytically generated base.

β -Ketosulfones (512) have been observed to undergo cathodic cleavage to (513) and (514) (Scheme 107).^{212,213} Either reduction or dimerization of (513) was found to take

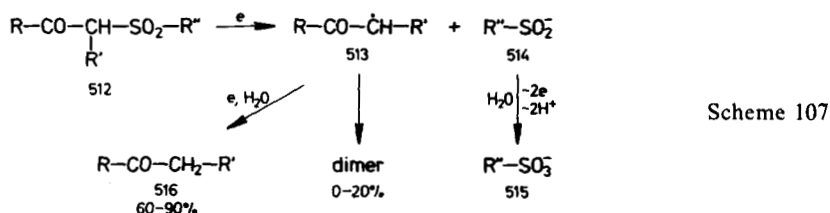

place giving rise to either (516) or dimer. Sulfinate (514) apparently underwent anodic oxidation to the corresponding sulfonate (515). The origin of the dimers formed as byproducts is most likely coupling of radicals rather than the result of $\text{S}_{\text{N}}2$ attack by reduced (513) on the substrate.²¹⁴ No unsymmetrical coupling product was found during the reduction of a mixture of two β -ketosulfones.

A polarographic study of the reduction of (517)–(522) was carried out to determine the

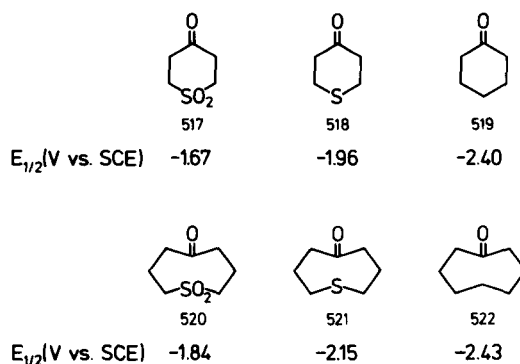

effect of transannular interactions on the ease of reduction.²¹⁵ Transannular interactions were observed to be significantly greater for the sulfone than the sulfide groups. The actual reduction process involves the keto group.

5. Unsaturated Sulfoxes.

Dependent upon the structure of (523) either cleavage to (497) and (524) or reduction of the double bond to give (525) is observed during electrolysis (Scheme 108).²¹⁶⁻²¹⁸

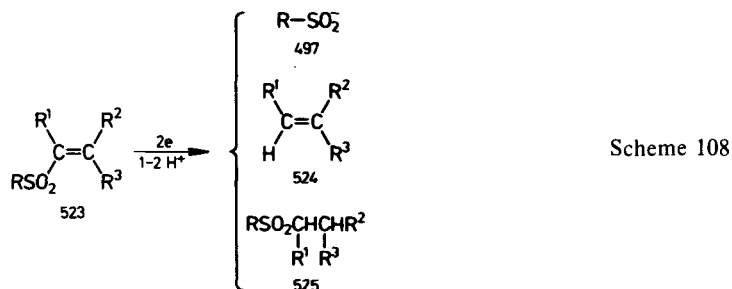

XVIII. DERIVATIVES OF SULFUR CONTAINING ACIDS

Sulfenic acid esters (526) have been reduced to the corresponding thiophenols (527) (Scheme 109).²¹⁹⁻²²⁰ Sulfinic acids (529) may be reduced to thiols as well (Scheme 110).²²¹

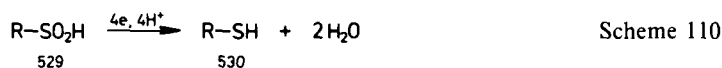
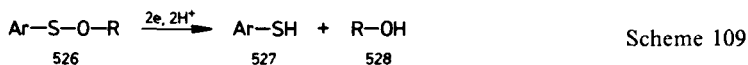

Sulfinate ions (531) can be oxidized on glassy carbon electrodes to dimer (532) in low yield (Scheme 111).²²² When the oxidation was carried out on mercury, a nearly quantitative yield of the mercury containing compound (533) was observed. During the reduction of

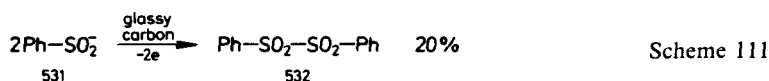

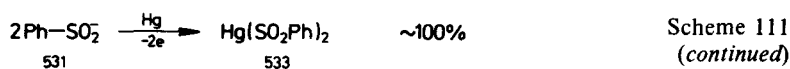

sulfonic acids either a hydrogen wave²²³ or a cleavage reaction (Scheme 112)²²⁴ have been reported. Sulfonic acid esters (536) can either cleave to give aryl radical (538) or radical

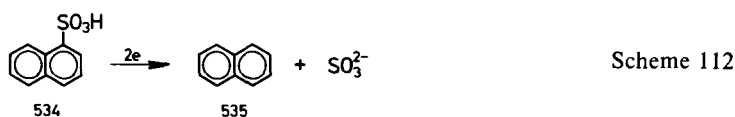

(543).²²⁵ Hydrolysis of (539) gives the alcohol (541) which can then react with substrate (536) to give ethers (546) and tosylate ion (547) (Scheme 113).²²⁵ The mode of cleavage

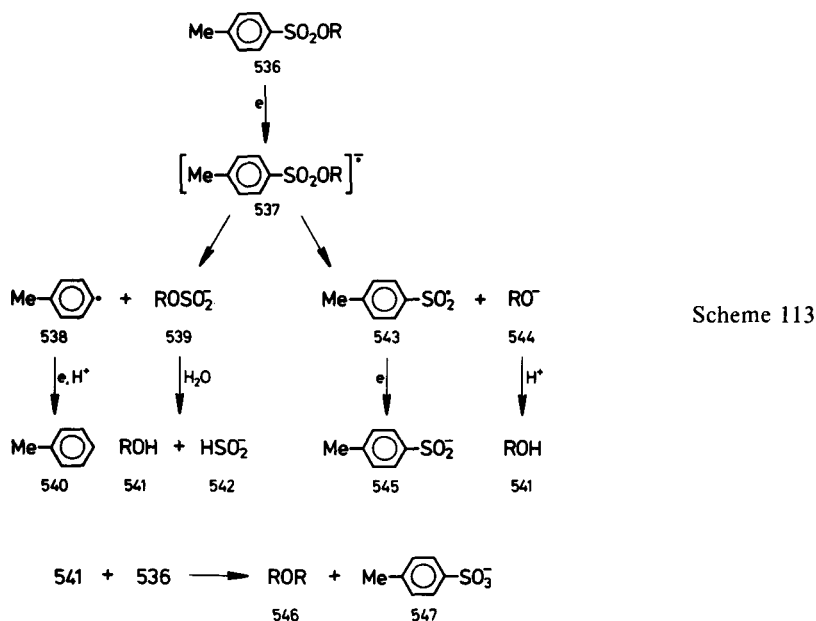

may be strongly affected by the stability of the resulting anions as is evident from the results of the cathodic reduction of (548) in which case only oxygen-carbon cleavage is observed (Scheme 114).²²⁶ Here again, the anionic product (549) was observed to react with substrate (548) in an S_N2 type reaction. Thiosulfonic esters (551) may also be reduced

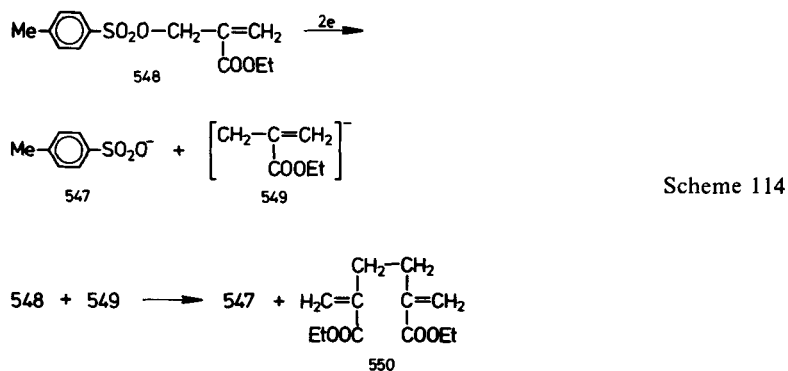

to thiols, in this case accompanied by equimolar amounts of sulfinate ions (Scheme 115).^{227,228} The reduction of sulfonyl chlorides can lead to a variety of products as is

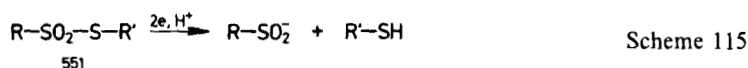

illustrated in Scheme 116.²²⁹ The Hammett equation was extended using polarographic reduction potentials of bisarylsulfonyl chlorides (556) in which the aryl groups were

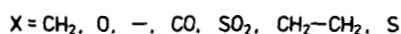
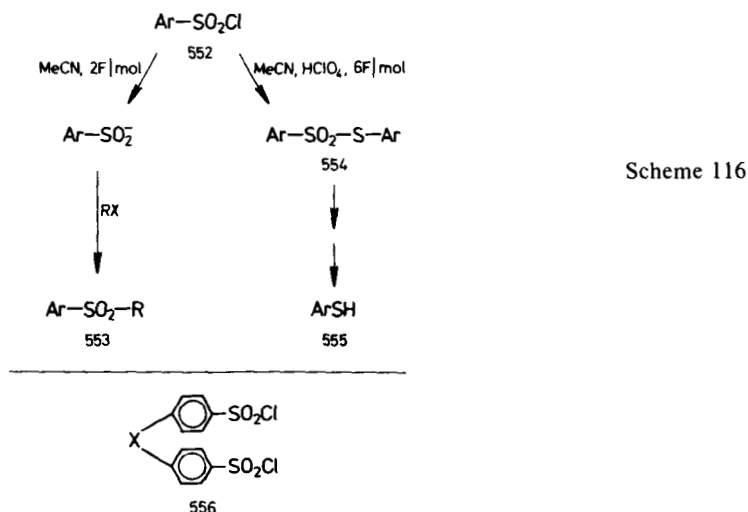

separated by various bridging groups.²³⁰ Sulfonamides (557) are reduced to give sulfinate ion (477) and amine (558) or if R is H cleavage takes place to give the hydrocarbon (559) and (560) which hydrolyzes to bisulfite ion and ammonia (Scheme 117).²³¹⁻²³⁶

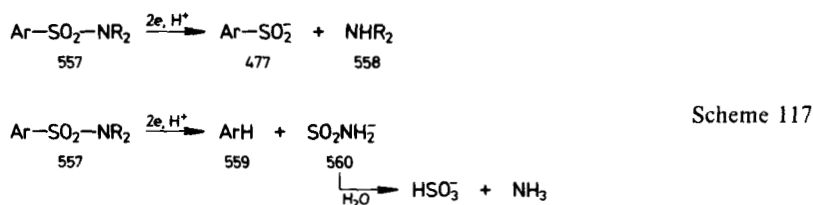

More details of the reactions covered briefly in this section can be found in a recent review.¹

XIX. THE PRESENT STATE OF THE ELECTROCHEMISTRY OF ORGANIC SULFUR COMPOUNDS

Except for the unusual interactions of organic sulfur compounds with mercury electrodes, the electrochemistry of these compounds does not differ in any essential way from that of others. Therefore in terms of the electrochemistry there is no particular advantage in considering them as a separate group. The present state of this topic is then that of

organic electrochemistry in general. Future work may show that there are more specific effects of the large sulfur atom in the electrode processes. Except for organic halogen compounds, sulfur compounds are the only class of substances with electronic configurations with higher orbitals than those encompassed by the second row elements that has been studied to any significant degree by electrochemical methods.

The synthetic aspects of organic sulfur compound electrochemistry are generally concerned with the conversion of functional groups and many useful procedures have evolved. As is the case in general, in recent years detailed mechanistic studies have been conducted as well. The present state of this area of endeavor is however not very well developed. For example, most of the schemes presented in this review are based on postulated mechanisms which have not been subjected to detailed mechanistic analysis. It can therefore be expected that more detailed studies will show that some of the postulated mechanisms are not correct descriptions of the processes. Even in some of the cases where very detailed studies have been carried out, the mechanisms are still in a stage of evolution. This is not the impression left upon the reader of some recent reviews in this area. For example, the half regeneration mechanism of the reactions of such species as thianthrene cation radical has been taken as established for the description of a number of processes.^{237,238} The term half regeneration arises from the fact that for each mole of product formed from the ion radical a mole of substrate is formed as in Scheme 40. Thus, half regeneration is a description of the stoichiometry of the reaction and will apply regardless of the detailed mechanism. The recent reviews^{237,238} have overlooked the fact that a significantly different mechanism has been reasonably well established for these reactions.^{85,88,89,239,240} This general mechanism has been shown in Scheme 45.

During the writing of this manuscript we became aware of another review²⁴¹ covering some of the aspects of the electrochemistry of organic sulfur compounds.

Acknowledgement. This work was carried out in part while V. D. P. was guest professor at the Department of General and Organic Chemistry, The H. C. Ørsted Institute. The Danish Natural Science Research Council provided O. H. with a grant covering travel expenses. We gratefully acknowledge this support. We also wish to express our gratitude to Mrs. E. Wedel who prepared the author index.

REFERENCES

1. J. Q. Chambers, in "Encyclopedia of Electrochemistry of the Elements", A. J. Bard and H. Lund, Eds. (Marcel Dekker, New York 1978) p. 329.
2. A. Swelim, A. I. A. Khodair and F. El-Sheikh, *Int. J. Sulfur Chem., B*, **6**, 195 (1971).
3. V. D. Parker in "Organic Electrochemistry, An Introduction and a Guide", M. M. Baizer, Ed. (Marcel Dekker, New York 1973), p. 551.
4. A. I. A. Khodair, A. Swelim and F. El-Sheikh, *Int. J. Sulfur Chem., B*, **6**, 213 (1971).
5. J. Q. Chambers, R. M. Harnden and N. D. Canfield, in "Characterization of Solutes in Nonaqueous Solvents", G. Mamantov, Ed. (Plenum Press, New York, 1978) p. 155.
6. "Organic Electrochemistry, 2nd Revised and Expanded Edition", M. M. Baizer and H. Lund, Eds. (Marcel Dekker, New York, to appear in 1982).
7. A. J. Bard and L. R. Faulkner, "Electrochemical Methods", (John Wiley and Sons, New York 1980).
8. S. Wawzonek and S. M. Heilmann, *J. Org. Chem.*, **39**, 511 (1974).
9. B. Fetkenheuer, H. Fetkenheuer and H. Lecus, *Chem. Ber.*, **60**, 2528 (1927).
10. U. Reuter and G. Gattow, *Z. Anorg. Allg. Chem.*, **421**, 143 (1976).
11. M. Falsig and H. Lund, *Acta Chem. Scand. Ser. B.*, **34**, 591 (1980).

12. M. Mizuno, M. P. Cava and A. F. Garito, *J. Org. Chem.*, **41**, 1484 (1976).
13. W. P. Krug, A. N. Bloch and D. O. Cowan, *J. C. S. Chem. Comm.*, 660 (1977).
14. M. F. Hurley and J. Q. Chambers, *J. Org. Chem.*, **46**, 775 (1981).
15. G. Bontempelli, F. Magno, G. A. Mazzocchin and R. Seeber, *J. Electroanal. Chem.*, **63**, 231 (1975).
16. J. L. Roberts, Jr. and D. T. Sawyer, *J. Electroanal. Chem.*, **9**, 1 (1965).
17. L. V. Haynes and D. T. Sawyer, *Anal. Chem.*, **39**, 332 (1967).
18. J. Q. Chambers, P. R. Moses, R. N. Shelton and D. L. Coffen, *J. Electroanal. Chem.*, **38**, 245 (1972).
19. P. R. Moses, J. Q. Chambers, J. O. Sutherland and D. R. Williams, *J. Electrochem. Soc.*, **122**, 608 (1975).
20. F. J. Goodman and J. Q. Chambers, *J. Org. Chem.*, **41**, 262 (1976).
21. M. Falsig and H. Lund, *Acta Chem. Scand. Ser. B.*, **34**, 545 (1980).
22. M. Falsig, H. Lund, L. Nadjo and J. M. Savéant, *Acta Chem. Scand. Ser. B.*, **34**, 685 (1980).
23. M. Falsig, H. Lund, L. Nadjo and J. M. Savéant, *Nouveau J. Chim.*, **4**, 445 (1980).
24. N. D. Canfield, J. Q. Chambers and D. L. Coffen, *J. Electroanal. Chem.*, **24**, App. 7 (1970).
25. P. R. Moses, R. M. Harnden and J. Q. Chambers, *J. Electroanal. Chem.*, **84**, 187 (1977).
26. R. M. Harnden, P. R. Moses and J. Q. Chambers, *J. C. S. Chem. Comm.*, 11 (1977).
27. P. R. Moses and J. Q. Chambers, *J. Electroanal. Chem.*, **49**, 105 (1974).
28. P. R. Moses and J. Q. Chambers, *J. Amer. Chem. Soc.*, **96**, 945 (1974).
29. R. D. Braun and D. C. Green, *J. Electroanal. Chem.*, **79**, 381 (1977).
30. C. Th. Pedersen and V. D. Parker, *Tetrahedron Letters*, 767 (1972).
31. C. Th. Pedersen, K. Bechgaard and V. D. Parker, *J. C. S. Chem. Comm.*, 430 (1972).
32. K. Bechgaard, V. D. Parker and C. Th. Pedersen, *J. Amer. Chem. Soc.*, **95**, 4373 (1973).
33. S. Hünig, B. J. Garner, G. Ruider and W. Schenk, *Liebigs Ann. Chem.*, 1036 (1973).
34. D. J. Sandman, T. J. Holmes and D. E. Warner, *J. Org. Chem.*, **44**, 880 (1979).
35. P. T. Kissinger, P. T. Holt and C. N. Reilly, *J. Electroanal. Chem.*, **33**, 1 (1971).
36. D. D. Macdonald, "Transient Techniques in Electrochemistry", (Plenum Press, New York 1977), chapter 5.
37. D. H. Geske, *J. Amer. Chem. Soc.*, **81**, 4145 (1959).
38. D. L. Coffen, J. Q. Chambers, D. R. Williams, P. E. Garrett and N. D. Canfield, *J. Amer. Chem. Soc.*, **93**, 2258 (1971).
39. K. W. Fung, J. Q. Chambers and G. Mamantov, *J. Electroanal. Chem.*, **47**, 81 (1973).
40. D. H. Geske and M. V. Merritt, *J. Amer. Chem. Soc.*, **91**, 6921 (1969).
41. S. Hünig, H. Schlaf, G. Kiesslich and D. Scheutzow, *Tetrahedron Letters*, 2271 (1969).
42. S. Hünig, G. Kiesslich, H. Quast and D. Scheutzow, *Liebigs Ann. Chem.*, 310 (1973).
43. A. Mas, J. M. Fabre, E. Torreilles, L. Giral and G. Brun, *Tetrahedron Letters*, 2579 (1977).
44. D. C. Green, *J. Org. Chem.*, **44**, 1476 (1979).
45. M. L. Kaplan, F. Wudl, R. C. Haddon and J. J. Hauser, *Chem. Scripta*, **15**, 196 (1980).
46. K. A. Idriss, J. Q. Chambers and D. C. Green, *J. Electroanal. Chem.*, **109**, 341 (1980).
47. J. Q. Chambers, D. C. Green, F. B. Kaufman, E. M. Engler, B. A. Scott and R. R. Schumaker, *Anal. Chem.*, **49**, 802 (1977).
48. R. C. Wheland and J. L. Gillson, *J. Amer. Chem. Soc.*, **98**, 3916 (1976).
49. C. D. Jaeger and A. J. Bard, *J. Amer. Chem. Soc.*, **101**, 1690 (1979).
50. K. Okamoto, *Bull. Chem. Soc. Japan*, **34**, 920 (1961).
51. Y. Hirabayashi and T. Mazume, *Bull. Chem. Soc. Japan*, **39**, 1971 (1966).
52. R. Woods, *Austr. J. Chem.*, **25**, 2329 (1972).
53. G. Cauquis and A. Deronzier, *J. C. S. Chem. Comm.*, 809 (1978).
54. R. Mayer, S. Scheithauer and D. Kunz, *Chem. Ber.*, **99**, 1393 (1966).
55. D. Kunz, S. Scheithauer and R. Mayer, *Z. Chem.*, **7**, 194 (1967).
56. J. Morgenstern, D. Kunz and R. Mayer, *Pharmazie*, **24**, 450 (1969).
57. J. Voss and K. Schlapkohl, *Tetrahedron*, **31**, 2982 (1975).
58. J. Voss, and W. Schmäser and K. Schlapkohl, *J. Chem. Res. (S)*, 144 (1977).
59. M. Falsig and H. Lund, *Acta Chem. Scand. Ser. B.*, **34**, 585 (1980).
60. K. Praefcke, C. Weichsel, M. Falsig and H. Lund, *Acta Chem. Scand. Ser. B.*, **34**, 403 (1980).
61. C. Th. Pedersen and V. D. Parker, *Tetrahedron Letters*, 771 (1972).
62. A. Astruc, M. Astruc, D. Gonbeau and G. Pfister-Guillouzo, *Coll. Czech. Chem. Comm.*, **39**, 861 (1974).
63. P. E. Iversen and H. Lund, *Acta Chem. Scand. Ser. B.*, **28**, 827 (1974).
64. C. Th. Pedersen, V. D. Parker and O. Hammerich, *Acta Chem. Scand. Ser. B.*, **30**, 478 (1976).
65. C. Th. Pedersen, O. Hammerich and V. D. Parker, *J. Electroanal. Chem.*, **38**, 479 (1972).
66. F. Gerson, R. Gleiter and H. Ohya-Nishiguchi, *Helv. Chim. Acta*, **60**, 1220 (1977).
67. W. Schroth, R. Borsdorf, R. Herzsuh and J. Seidler, *Z. Chem.*, **10**, 147 (1970).
68. O. Hammerich and V. D. Parker, to be published.

69. H. J. Shine, C. F. Dais and R. J. Small, *J. Org. Chem.*, **29**, 21 (1964).
70. C. Barry, G. Cauquis and M. Maurey, *Bull. Soc. Chim. France*, 2510 (1966).
71. A. Zweig and A. K. Hoffmann, *J. Org. Chem.*, **30**, 3997 (1965).
72. W. E. Geiger, Jr., *J. Phys. Chem.*, **77**, 1862 (1973).
73. H. J. Shine and L. Piette, *J. Amer. Chem. Soc.*, **84**, 4798 (1962).
74. H. E. Imberger and A. A. Humffray, *Electrochim. Acta*, **18**, 373 (1973).
75. Y. Murata and H. J. Shine, *J. Org. Chem.*, **34**, 3368 (1969).
76. V. D. Parker and L. Ebersson, *J. Amer. Chem. Soc.*, **92**, 7488 (1970).
77. R. S. Glass, W. J. Britt, W. N. Miller and G. S. Wilson, *J. Amer. Chem. Soc.*, **95**, 2375 (1973).
78. I. B. Goldberg, H. R. Crowe, G. S. Wilson and R. S. Glass, *J. Phys. Chem.*, **80**, 988 (1976).
79. O. Hammerich and V. D. Parker, *Electrochim. Acta*, **18**, 537 (1973).
80. O. Hammerich and V. D. Parker, *J. Electroanal. Chem.*, **36**, App. 11 (1972).
81. C. Madec and J. Courtot-Coupez, *J. Electroanal. Chem.*, **84**, 169 (1977).
82. O. Hammerich, N. S. Moe and V. D. Parker, *J. C. S. Chem. Comm.*, 156 (1972).
83. L. A. Tinker and A. J. Bard, *J. Amer. Chem. Soc.*, **101**, 2316 (1979).
84. J. F. Evans and H. N. Blount, *J. Org. Chem.*, **42**, 976 (1977).
85. O. Hammerich and V. D. Parker, *Acta Chem. Scand. Ser. B*, in press.
86. J. J. Silber and H. J. Shine, *J. Org. Chem.*, **36**, 2923 (1971).
87. K. Kim, V. J. Hull and H. J. Shine, *J. Org. Chem.*, **39**, 2534 (1974).
88. U. Svanholm, O. Hammerich and V. D. Parker, *J. Amer. Chem. Soc.*, **97**, 101 (1975).
89. U. Svanholm and V. D. Parker, *J. Amer. Chem. Soc.*, **98**, 997 (1976).
90. A. Dusserre and M. Genies, *Bull. Soc. Chim. France*, 1-282 (1979).
91. M. Janda, *Coll. Czech. Chem. Comm.*, **28**, 2524 (1963).
92. M. Janda and L. Pavienský, *Coll. Czech. Chem. Comm.*, **32**, 2675 (1967).
93. N. Clauson-Kaas, F. Limborg and K. Glens, *Acta Chem. Scand.*, **6**, 531 (1952).
94. D. L. Hufford, D. S. Tarbell and T. R. Koszalka, *J. Amer. Chem. Soc.*, **74**, 3014 (1954).
95. M. Janda and J. Radouch, *Coll. Czech. Chem. Comm.*, **32**, 2672 (1967).
96. J. Šrogl, M. Janda, I. Stibor, J. Kos and Vyskočil, *Coll. Czech. Chem. Comm.*, **43**, 2015 (1978).
97. J. Šrogl, M. Janda, I. Stibor and Z. Salajka, *Coll. Czech. Chem. Comm.*, **42**, 1361 (1977).
98. I. Stibor, J. Šrogl and M. Janda, *J. C. S. Chem. Comm.*, 397 (1975).
99. N. Kucharczyk, M. Adamovský, V. Horák and P. Zuman, *J. Electroanal. Chem.*, **10**, 503 (1965).
100. L. S. R. Yeh and A. J. Bard, *J. Electroanal. Chem.*, **70**, 157 (1976).
101. L. S. R. Yeh and A. J. Bard, *J. Electroanal. Chem.*, **81**, 319 (1977).
102. L. S. R. Yeh and A. J. Bard, *J. Electroanal. Chem.*, **81**, 333 (1977).
103. G. Bontempelli, F. Magno, G. A. Mazocchin and S. Zecchin, *J. Electroanal. Chem.*, **43**, 377 (1973).
104. I. M. Kolthoff and J. J. Lingane, "Polarography", Vol. 2, (Interscience, New York, 1952).
105. F. Magno, G. Bontempelli and G. Pilloni, *J. Electroanal. Chem.*, **30**, 375 (1971).
106. J. J. Donahue and J. W. Olver, *Anal. Chem.*, **41**, 753 (1969).
107. J. K. Howie, J. J. Houts and D. T. Sawyer, *J. Amer. Chem. Soc.*, **99**, 6323 (1977).
108. D. Kunz, H. Hartmann and R. Mayer, *Z. Chem.*, **9**, 60 (1969).
109. C. Degrand and H. Lund, *Acta Chem. Scand. Ser. B*, **33**, 512 (1979).
110. C. Degrand and H. Lund, *C. R. Acad. Sci. Paris, Ser. C*, **291**, 295 (1980).
111. F. Pragst, *J. Electroanal. Chem.*, **119**, 315 (1981).
112. I. M. Kolthoff and C. Barnum, *J. Amer. Chem. Soc.*, **62**, 3061 (1940).
113. W. Stricks and I. M. Kolthoff, *J. Amer. Chem. Soc.*, **74**, 4646 (1952).
114. R. S. Saxena and S. K. Bhatia, *Electrochim. Acta*, **18**, 933 (1973).
115. S. G. Mairanovskii, L. K. Gladkova, A. A. Pozdeeva and F. M. Stoyanovich, *Soviet Electrochem.*, **8**, 571 (1972).
116. B. Persson and B. Nygård, *J. Electroanal. Chem.*, **56**, 373 (1974).
117. J. Simonet and P. Martinet, *J. Electroanal. Chem.*, **88**, 425 (1978).
118. I. M. Kolthoff and C. Barnum, *J. Amer. Chem. Soc.*, **63**, 520 (1941).
119. I. R. Miller and J. Teva, *J. Electroanal. Chem.*, **36**, 157 (1972).
120. I. M. Issa, A. A. El Samahy, R. M. Issa and Y. M. Temerik, *Electrochim. Acta*, **17**, 1615 (1972).
121. J. Koryta and J. Pradac, *J. Electroanal. Chem.*, **17**, 177 (1968).
122. J. Koryta and J. Pradac, *J. Electroanal. Chem.*, **17**, 185 (1968).
123. J. Pradac and J. Koryta, *J. Electroanal. Chem.*, **17**, 167 (1968).
124. D. G. Davis and E. Bianco, *J. Electroanal. Chem.*, **12**, 254 (1966).
125. G. Dryhurst, *J. Electrochem. Soc.*, **116**, 1357 (1969).
126. G. Dryhurst, *J. Electrochem. Soc.*, **117**, 1118 (1970).
127. G. Dryhurst, *J. Electroanal. Chem.*, **28**, 33 (1970).

128. H. Lund, *Acta Chem. Scand.*, **21**, 2525 (1967).
129. G. Bontempelli, F. Magno and G. A. Mazzachin, *J. Electroanal. Chem.*, **42**, 57 (1973).
130. A. Bewick, D. E. Coe, J. M. Mellor and D. J. Walton, *J. C. S. Chem. Comm.*, 51 (1980).
131. A. Zweig, and J. E. Lehnsen, *J. Amer. Chem. Soc.*, **87**, 2647 (1965).
132. A. Zweig, A. H. Maurer and B. G. Roberts, *J. Org. Chem.*, **32**, 1322 (1967).
133. R. Breslow, R. W. Johnson and A. Krebs, *Tetrahedron Letters*, 3443 (1975).
134. G. S. Wilson, D. D. Swanson, J. T. Klug, R. S. Glass, M. D. Ryan and W. K. Musker, *J. Amer. Chem. Soc.*, **101**, 1040 (1979).
135. M. D. Ryan, D. D. Swanson, R. S. Glass and G. S. Wilson, *J. Phys. Chem.*, **85**, 1069 (1981).
136. R. S. Glass, J. R. Duchek, J. T. Klug and G. S. Wilson, *J. Amer. Chem. Soc.*, **99**, 7349 (1977).
137. P. T. Cottrell and C. K. Mann, *J. Electrochem. Soc.*, **116**, 1499 (1969).
138. S. Torii, Y. Matsuyama, K. Kawasaki and K. Uneyama, *Bull. Chem. Soc. Japan*, **46**, 2912 (1973).
139. F. Magno and G. Bontempelli, *J. Electroanal. Chem.*, **36**, 389 (1972).
140. K. Uneyama and S. Torii, *J. Org. Chem.*, **37**, 367 (1972).
141. K. Uneyama and S. Torii, *Tetrahedron Letters*, 329 (1971).
142. M. M. Nicholson, *J. Amer. Chem. Soc.*, **76**, 2539 (1954).
143. F. Fichter and P. Sjöstedt, *Chem. Ber.*, **43**, 3422 (1910).
144. D. S. Houghton and A. A. Humffray, *Electrochim. Acta*, **17**, 1421 (1972).
145. A. A. Humffray and D. S. Houghton, *Electrochim. Acta*, **17**, 1435 (1972).
146. K. Uneyama, S. Torii and S. Oae, *Bull. Chem. Soc. Japan*, **44**, 815 (1971).
147. T. Shono, Y. Matsumura, M. Mizoguchi and J. Hayashi, *Tetrahedron Letters*, 3861 (1979).
148. J. G. Gourcy, G. Jeminet and J. Simonet, *J. C. S. Chem. Comm.*, 634 (1974).
149. N. D. Canfield and J. Q. Chambers, *J. Electroanal. Chem.*, **56**, 459 (1974).
150. Q. N. Porter and J. H. P. Utley, *J. C. S. Chem. Comm.*, 255 (1978).
151. P. Martigny and J. Simonet, *J. Electroanal. Chem.*, **111**, 133 (1980).
152. M. Platen and E. Steckhan, *Tetrahedron Letters*, **26**, 511 (1980).
153. J. Gourcy, P. Martigny, J. Simonet and G. Jeminet, *Tetrahedron*, **37**, 1495 (1981).
154. J. Nokami, N. Matsuura, T. Sueoka, O. Kusumoto and M. Kawada, *Chem. Lett.*, 1283 (1978).
155. J. Nokami, M. Kawada, R. Okawara, S. Torii and H. Tanaka, *Tetrahedron Letters*, 1045 (1979).
156. S. Torii, T. Inokuchi and N. Takahasi, *J. Org. Chem.*, **43**, 5020 (1978).
157. A. Matsumoto, K. Suda and C. Yijima, *J. C. S. Chem. Comm.*, 263 (1981).
158. R. Gerdil, *J. Chem. Soc. (B)*, 1071 (1966).
159. H. Lund, *Acta Chem. Scand.*, **14**, 1927 (1960).
160. C. P. Andrieux and J. M. Savéant, *Bull. Chim. Soc. France*, 3281 (1972).
161. J. Moiroux and M. B. Fleury, *Electrochim. Acta*, **18**, 691 (1973).
162. C. M. Fischer and R. E. Erickson, *J. Org. Chem.*, **38**, 4236 (1973).
163. T. Shono, Y. Matsumura, S. Kashimura and H. Kyutoku, *Tetrahedron Letters*, 2807 (1978).
164. C. S. Liao, J. Q. Chambers, I. Kapovits and J. Rabai, *J. C. S. Chem. Comm.*, 149 (1974).
165. D. E. Bartak, T. M. Shields and M. D. Hawley, *J. Electroanal. Chem.*, **30**, 289 (1971).
166. R. Herzschuh and R. Borsdorf, *J. Electroanal. Chem.*, **23**, 55 (1969).
167. A. J. Fry, K. Anker and V. Handa, *Tetrahedron Letters*, **22**, 1791 (1981).
168. M. Finkelstein, R. C. Petersen and S. D. Ross, *J. Electrochem. Soc.*, **110**, 422 (1963).
169. A. Lüttringhaus and H. Machatzke, *Liebigs Ann. Chem.*, **671**, 165 (1964).
170. W. A. Bonner, *J. Amer. Chem. Soc.*, **74**, 5078 (1952).
171. P. S. McKinney and S. Rosenthal, *J. Electroanal. Chem.*, **16**, 261 (1968).
172. E. A. H. Hall and L. Horner, *Ber. Bunsenges. Phys. Chem.*, **84**, 1145 (1980).
173. J. H. Wagenknecht and M. M. Baizer, *J. Electrochem. Soc.*, **114**, 1095 (1967).
174. T. Shono and M. Mitani, *J. Amer. Chem. Soc.*, **90**, 2728 (1968).
175. T. Shono, T. Akazawa and M. Mitani, *Tetrahedron*, **29**, 817 (1973).
176. T. Shono and M. Mitani, *Tetrahedron Letters*, 687 (1969).
177. M. M. Baizer, *J. Org. Chem.*, **31**, 3847 (1966).
178. G. Sartori and C. Furlani, *Ann. Chim. (Rome)*, **44**, 95 (1954).
179. A. Mehlhorn, J. Fabian and R. Mayer, *Z. Chem.*, **5**, 21 (1965).
180. R. M. Eloffson, F. F. Gadallah and L. A. Gadallah, *Can. J. Chem.*, **47**, 3979 (1969).
181. R. O. Loutfy, *J. Phys. Chem.*, **76**, 1650 (1972).
182. C. Párkányi and R. Zahradnik, *Coll. Czech. Chem. Comm.*, **27**, 1355 (1962).
183. D. Kunz, S. Scheithauer, S. Bleisch and R. Mayer, *J. Prakt. Chem.*, **312**, 426 (1970).
184. P. Berstein and M. N. Hull, *J. Electroanal. Chem.*, **28**, App. 1 (1970).
185. R. C. Bowers and H. D. Russell, *Anal. Chem.*, **32**, 405 (1960).
186. L. Suchomelova, J. Zýka and P. Zuman, *J. Electroanal. Chem.*, **12**, 194 (1966).

187. G. Grandi, L. Benedetti, R. Andreoli and G. Battistuzzi Gavioli, *J. Electroanal. Chem.*, **54**, 221 (1974).
188. B. Lamm and B. Samuelsson, *Acta Chem. Scand.*, **23**, 691 (1969).
189. T. D. Binns and R. Brettle, *J. Chem. Soc. (C)*, 336 (1966).
190. B. Samuelsson and B. Lamm, *J. C. S. Perkin I*, 652 (1972).
191. A. J. Fry, K. Ankner and V. K. Handa, *J. C. S. Chem. Comm.*, 120 (1981).
192. S. Torii and K. Uneyama, *Tetrahedron Letters*, 4513 (1972).
193. G. Bomtempelli, F. Magno, G. A. Mazzocchin and R. Seeber, *J. Electroanal. Chem.*, **55**, 109 (1974).
194. J. A. Cox and C. L. Ozment, *J. Electroanal. Chem.*, **51**, 75 (1974).
195. R. Gerdil, *Helv. Chim. Acta*, **56**, 196 (1973).
196. F. de Jong and M. Janssen, *J. Chem. Soc. Perkin II*, 572 (1972).
197. J. Grimshaw and J. Trocha-Grimshaw, *J. C. S. Perkin I*, 799 (1979).
198. L. Horner and E. Meyer, *Ber. Bunsenges. Phys. Chem.*, **79**, 136 (1975).
199. L. Horner and E. Meyer, *Ber. Bunsenges. Phys. Chem.*, **79**, 143 (1975).
200. L. Horner and E. Meyer, *Liebigs Ann. Chem.*, 2053 (1975).
201. O. Manousek, O. Exner and P. Zuman, *Coll. Czech. Chem. Comm.*, **33**, 3988 (1968).
202. J. Simonet and G. Jeminet, *Bull. Soc. Chim. France*, 2754 (1971).
203. B. Lamm and K. Ankner, *Acta Chem. Scand. Ser. B*, **32**, 264 (1978).
204. B. Lamm and B. Samuelsson, *Acta Chem. Scand.*, **24**, 561 (1970).
205. B. Lamm, *Tetrahedron Letters*, 1469 (1972).
206. B. Lamm and J. Simonet, *Acta Chem. Scand. Ser. B*, **28**, 147 (1974).
207. J. Simonet and H. Lund, *Acta Chem. Scand. Ser. B*, **31**, 909 (1977).
208. G. Jeminet, J. G. Gourcy and J. Simonet, *Tetrahedron Letters*, 2975 (1972).
209. B. Lamm and K. Ankner, *Acta Chem. Scand. Ser. B*, **32**, 31 (1978).
210. A. J. Bellamy and I. S. MacKirdy, *J. C. S. Perkin II*, 1093 (1981).
211. S. Gambino, P. Martigny, G. Mousset and J. Simonet, *J. Electroanal. Chem.*, **90**, 105 (1978).
212. B. Lamm and B. Samuelsson, *Acta Chem. Scand.*, **24**, 561 (1970).
213. B. Samuelsson and B. Lamm, *Acta Chem. Scand.*, **24**, 3070 (1970).
214. B. Lamm and B. Samuelsson, *J. C. S. Chem. Comm.*, 1010 (1970).
215. H. Remane, R. Herzschuh, L. C. Hoa and R. Borsdorf, *J. Electroanal. Chem.*, **35**, 363 (1972).
216. C. W. Johnson, C. G. Overberger and W. J. Seagers, *J. Amer. Chem. Soc.*, **75**, 1495 (1953).
217. E. A. Berdnikov, Yu. M. Kargin and F. R. Tantasheva, *J. Gen. Chem. USSR*, **44**, 1341 (1974).
218. K. Ankner, B. Lamm and J. Simonet, *Acta Chem. Scand. Ser. B*, **31**, 742 (1977).
219. Z. V. Todres, K. P. Butin and S. P. Avagyan, *Bull. Acad. Sci. USSR, Div. Chem. Sci.*, 67 (1974).
220. B. J. Lindberg, *Acta Chem. Scand.*, **24**, 1110 (1970).
221. B. Fleszar and P. Sanecki, *Electrochim. Acta*, **25**, 551 (1980).
222. B. Persson, *Acta Chem. Scand. Ser. B*, **31**, 88 (1977).
223. L. Horner and H. Nickel, *Chem. Ber.*, **89**, 1681 (1956).
224. E. S. Levin and N. A. Osipova, *J. Gen. Chem. USSR*, **32**, 2060 (1962).
225. P. Yousefzadeh and C. K. Mann, *J. Org. Chem.*, **33**, 2716 (1968).
226. J. P. Petrovich and M. M. Baizer, *Electrochim. Acta*, **12**, 1249 (1967).
227. B. G. Boldyrev, M. A. Kovbuz and T. A. Trofimova, *Zh. Obshch. Khim.*, **35**, 22 (1965). *CA*, **62**, 13023h (1965).
228. L. Field and R. B. Barbee, *J. Org. Chem.*, **34**, 1792 (1969).
229. G. Jeminet, J. Simonet and J. G. Gourcy, *Bull. Soc. Chim. France*, 1102 (1974).
230. P. Sanecki and B. Fleszar, *Polish J. Chem.*, **42**, 1753 (1978).
231. P. T. Cottrell and C. K. Mann, *J. Amer. Chem. Soc.*, **93**, 3579 (1971).
232. L. Horner and R. J. Singer, *Liebigs Ann. Chem.*, **723**, 1 (1969).
233. L. Horner and H. Neumann, *Chem. Ber.*, **98**, 3462 (1965).
234. O. Manousek, O. Exner and P. Zuman, *Coll. Czech. Chem. Comm.*, **33**, 4000 (1968).
235. A. I. Cohen, B. T. Keeler, N. H. Coy and H. L. Yale, *Anal. Chem.*, **34**, 216 (1962).
236. P. Zuman, *Z. Anal. Chem.*, **224**, 374 (1967).
237. H. N. Blount and J. F. Evans in "Characterization of Solutes in Nonaqueous Solvents", G. Mamantov, Ed. (Plenum Press, New York, 1978) p. 105.
238. H. J. Shine in "The Chemistry of the Sulfonium Group", C. J. M. Stirling and S. Patai, Eds. (John Wiley and Sons, New York 1981) p. 523.
239. U. Svanholm and V. D. Parker, *J. Amer. Chem. Soc.*, **98**, 2942 (1976).
240. U. Svanholm and V. D. Parker, *Acta Chem. Scand. Ser. B*, **34**, 5 (1980).
241. J. Grimshaw in "The Chemistry of the Sulfonium Group", C. J. M. Stirling and S. Patai, Eds. (John Wiley and Sons, New York 1981) p. 141.